

# Lighting strips

## DISPLAY ILLUMINATION

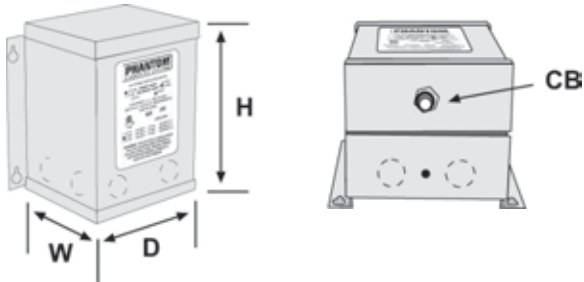

ETL LISTED, MISCELLANEOUS FIXTURES, CONFORMS TO UL STD. 1598

# TRANSFORMERS

## MAGNETIC POWER SUPPLY

### LOW VOLTAGE STRIP

SPECIFICATIONS	100 VA	150 VA	250 VA	500 VA	750 VA	1000 VA	1200 VA
MAXIMUM WATTAGE	80	120	200	400	600	800	1000
HEIGHT (H)	6 3/4"	6 3/4"	6 3/4"	8 1/4"	8 1/4"	8 1/4"	10 1/4"
WIDTH (W)	4 7/8"	4 7/8"	4 7/8"	5 5/8"	5 5/8"	5 5/8"	5 5/8"
DEPTH (D)	4 5/8"	4 5/8"	4 5/8"	5 1/4"	5 1/4"	5 1/4"	5 1/4"
12 VOLT (CB)	(1) 10A	(1) 15A	(1) 25A	(2) 25A	(3) 25A	(4) 25A	
24 VOLT (CB)	(1) 5A	(1) 7A	(1) 10A	(1) 25A	(2) 15A	(2) 25A	(2) 25A
WEIGHT (LBS)	10	11	13	19	19	28	28
12V PART #'s	MT102	MT152	MT252	MT502	MT752	MT1002	
24V PART #'s	MT104	MT154	MT254	MT504	MT754	MT1004	MT1204

To figure total requirements for transformers, calculate total watts per foot divided by voltage equals total amperage. (watts / voltage = amperage). Refer to the table to calculate wire size and fusing requirements.

### VOLTAGE / WATTAGE

SPACING	WATTS/VOLTS		1'	2'	3'	4'	5'	6'	7'	8'	9'	10'
4"	0.6W / 12V LED	WATTAGE	1.80	3.60	5.40	7.20	9.00	10.80	12.60	14.40	16.20	18.00
		AMPERAGE	0.15	0.30	0.45	0.60	0.75	0.90	1.05	1.20	1.35	1.50
	0.6W / 24V LED	WATTAGE	1.80	3.60	5.40	7.20	9.00	10.80	12.60	14.40	16.20	18.00
		AMPERAGE	0.08	0.15	0.23	0.30	0.38	0.45	0.53	0.60	0.68	0.75
4"	3W / 12V XENON / INCANDESCENT	WATTAGE	9	18	27	36	45	54	63	72	81	90
		AMPERAGE	0.75	1.50	2.25	3.00	3.75	4.50	5.25	6.00	6.75	7.50
	3W / 24V XENON / INCANDESCENT	WATTAGE	9	18	27	36	45	54	63	72	81	90
		AMPERAGE	0.38	0.75	1.13	1.50	1.88	2.25	2.63	3.00	3.38	3.75
4"	5W / 12V XENON / INCANDESCENT	WATTAGE	15	30	45	60	75	90	105	120	135	150
		AMPERAGE	1.25	2.50	3.75	5.00	6.25	7.50	8.75	10.00	11.25	12.5
	5W / 24V XENON / INCANDESCENT	WATTAGE	15	30	45	60	75	90	105	120	135	150
		AMPERAGE	0.63	1.25	1.88	2.50	3.13	3.75	4.38	5.00	5.63	6.25
4"	10W / 12V XENON / INCANDESCENT	WATTAGE	30	60	90	120	150	X	X	X	X	X
		AMPERAGE	2.50	5.00	7.50	10.00	12.50	X	X	X	X	X
	10W / 24V XENON / INCANDESCENT	WATTAGE	30	60	90	120	150	180	210	240	270	300
		AMPERAGE	1.25	2.50	3.75	5.00	6.25	7.50	8.75	10.00	11.25	12.50
6"	0.6W / 12V LED	WATTAGE	1.20	2.40	3.60	4.80	6.00	7.20	8.40	9.60	10.80	12.00
		AMPERAGE	0.10	0.20	0.30	0.40	0.50	0.60	0.70	0.80	0.91	1.00
	0.6W / 24V LED	WATTAGE	1.20	2.50	3.60	4.80	6.00	7.20	8.40	9.60	10.80	12.00
		AMPERAGE	0.05	0.10	0.15	0.20	0.25	0.30	0.35	0.40	0.45	0.50
6"	3W / 12V XENON / INCANDESCENT	WATTAGE	6	12	18	24	30	36	42	48	54	60
		AMPERAGE	0.50	1.00	1.50	2.00	2.50	3.00	3.50	4.00	4.50	5.00
	3W / 24V XENON / INCANDESCENT	WATTAGE	6	12	18	24	30	36	42	48	54	60
		AMPERAGE	0.25	0.50	0.75	1.00	1.25	1.50	1.75	2.00	2.25	2.50
6"	5W / 12V XENON / INCANDESCENT	WATTAGE	10	20	30	40	50	60	70	80	90	100
		AMPERAGE	0.83	1.67	2.50	3.33	4.17	5.00	5.83	6.67	7.50	8.33
	5W / 24V XENON / INCANDESCENT	WATTAGE	10	20	30	40	50	60	70	80	90	100
		AMPERAGE	0.42	0.83	1.25	1.67	2.08	2.50	2.92	3.33	3.75	4.17
6"	10W / 12V XENON / INCANDESCENT	WATTAGE	20	40	60	80	100	120	140	160	X	X
		AMPERAGE	1.67	3.33	5.00	6.67	8.33	10.00	11.67	13.33	X	X
	10W / 24V XENON / INCANDESCENT	WATTAGE	20	40	60	80	100	120	140	160	180	200
		AMPERAGE	0.83	1.67	2.50	3.33	4.17	5.00	5.83	6.67	7.50	8.33

**WARNING: THERE IS A LIMIT ON HOW MANY PHANTOM FIXTURES CAN BE CONNECTED IN TANDEM. NO CIRCUIT SHALL EXCEED 160 WATTS ON 12V AND 320 WATTS ON 24V. MAXIMUM FEED THRU CAPACITY SHALL NOT EXCEED 13.33 AMPS.**

**SECONDARY WIRING DIAGRAMS**

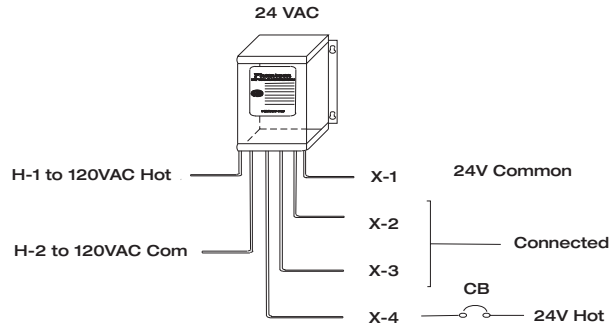
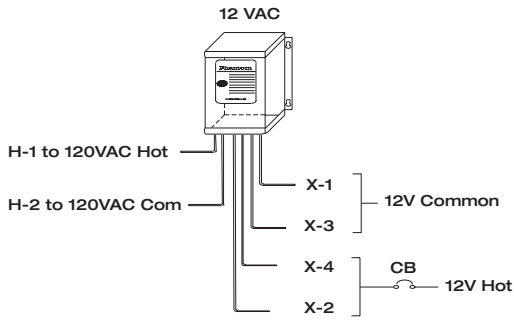

**SECONDARY WIRING EXAMPLES**

Just because you are installing a low voltage system, it doesn't mean that you can use low voltage wire! In fact, low voltage current operates at higher amperage levels than standard 120 volt systems. The current is 10 times greater for a 12 volt system than for a 120 volt system of the same wattage. Consequently, you must use larger wire sizes for 12 and 24 volt systems to minimize voltage drop and to handle the amperage loads. It is always best to locate your transformer adjacent to the lights, in the center of the run or as short a distance as possible to maintain lumen output. When at all possible, voltage drop should be limited to 5% loss between the transformer and the lighting strips.

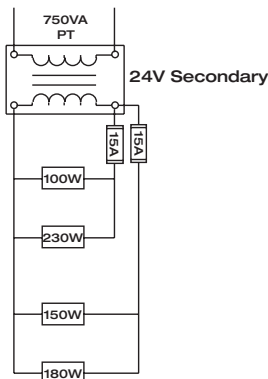
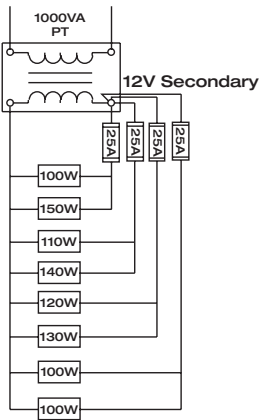
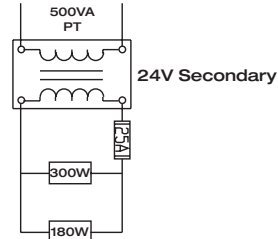
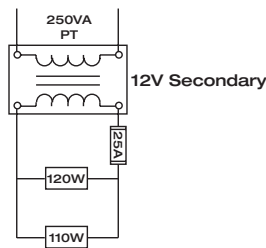

**TERMS AND CONDITIONS**

To comply with Phantom Lighting System warranty policies and ETL Standards, all lighting strips must be used in conjunction with Phantom lighting transformers. All Phantom lighting transformers are ETL Approved for Class 1 applications and are strongly recommended for proper operation of lighting strips. Phantom transformers should not be located in areas with no ventilation or subject to high ambient temperatures. If ambient temperatures exceed 115°F (46°C) around the transformer the circuit breakers may nuisance-trip due to excessive heat. CAUTION: FAILURE TO CORRECTLY SIZE PRIMARY AND SECONDARY CONDUCTORS AND OR OVERLOAD PROTECTION MAY RESULT IN BODILY INJURY OR SERIOUS PROPERTY DAMAGE.

Likewise, Phantom lighting strips should be installed in such a way as to properly dissipate heat. We recommend that you allow a minimum overall 3" set back from the wall or ceiling plane being illuminated. Not only does this clearance allow the heat to escape, but it allows room for installation, servicing and changing lamps. If you are using exotic wood, veneers or heat sensitive fabrics we suggest increasing this clearance from a 3" to 5" set back.

If you have any questions or concerns regarding your application, please contact the factory, a licensed electrician or consult the National Electric Code.



607 Durham Drive | Houston, Texas 77007-5316  
 Tel: 713.863.1133 | Fax: 713.863.0044 | 800.863.1184  
[www.phantomlighting.com](http://www.phantomlighting.com)  
 © Copyright 2010 Phantom Lighting Systems