



CABINET LIGHTING

HORIZONTAL MOUNTING SERIES



CLASSIC LEVEL

Horizontal Mount Shelf Lighting

Phantom™ Classic HM Series light strips provide the ultimate performance and flexibility as a seamless, concealed low voltage linear lighting source. All Phantom HM Series lighting strips are manufactured to your exact specifications using a variety of custom metal glare shields, so that the light is always perfectly controlled while keeping the fixture out of sight. Lamping options include 3 watt, 5 watt, and 10 watt Xenon festoon lamps (rated for up to 20,000 hours) and LED lamps (rated for up to 40,000 hours). Energy-efficient 0.6 watt 12VAC LED lamps are ideal for applications where energy code compliance is an issue or a major consideration.

All lamping options are fully dimmable for achieving the perfect light level or to extend lamp life. Phantom HM series light strips are available unfinished or in eight painted colors. Please contact the factory if you're interested in our custom color options. Phantom Lighting is all about seeing the light, not the fixture.

PHANTOM CLASSIC HM SERIES FEATURES

- Designed for hard wiring applications such as antiques, free standing furniture, or built-in bookshelves where the shelves are fixed in place
- Paint grip galvanized metal trim with unique glare shields specifically designed for horizontal shelves or display lighting applications
- Multiple trim shapes available for custom applications or for use above eye-level
- LED and Xenon festoon lamping options
- ETL Listed, Miscellaneous fixtures, conforms to UL STD, 1598

Classic HM Series Exploded View

LIGHTING STRIP

Each lighting strip may contain one or more festoon lamps with spacing 4 or 6 inches on center. For best results, always use a matte finish on the back of the cabinet to minimize reflections or glare.

DIMMER CONTROLS (BY OTHERS)

Magnetic low voltage transformers should always be used with a dimmer designated for magnetic or inductive loads. Electronic transformers should always be used with a dimmer designated for electronic loads.

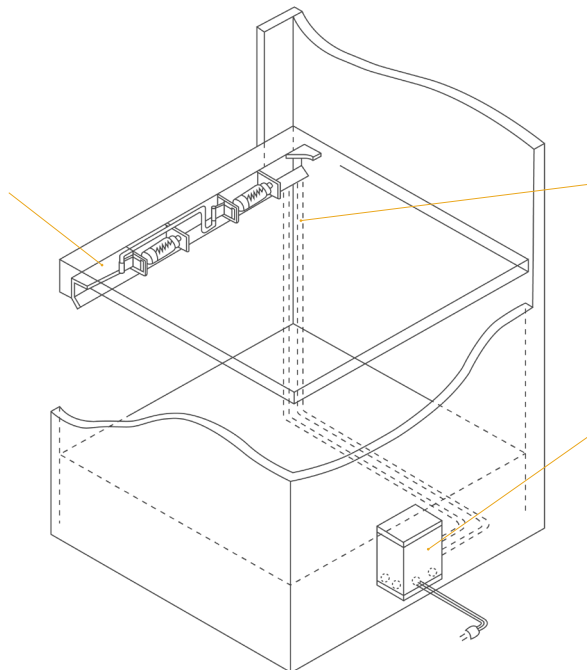

CONCEALED WIRING

For fixed shelving, furniture or retrofit applications, it may be necessary to conceal wiring from individual fixtures back to the transformer. We are happy to manufacture your lighting strips with long leads to accommodate any application. Consult factory for other fixed wiring methods.

TRANSFORMERS

Magnetic transformers are sized to match the total wattage of your lighting load and come equipped with one or more secondary circuit breakers. (See driver sheet for more sizing information and amperage calculations).

Classic HM Series Trim Profiles

Phantom offers a variety of trim profiles to suit any lighting application. Choose your trim profile based on your mounting application and the level of glare desired.

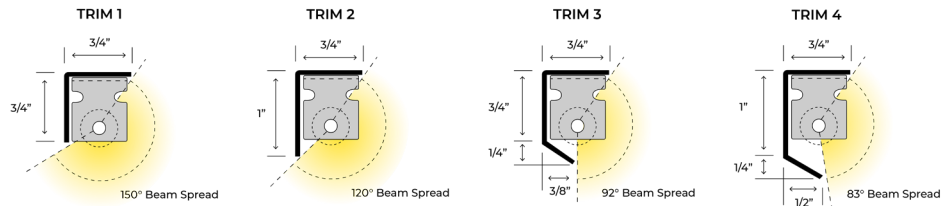

Classic HM Series Lamps

Xenon festoon lamps are available in 3 watt, 5 watt, and 10 watt, in both 12VAC and 24VAC. Xenon lamps (2,800°K) typically produce a whiter light and are used for display lighting. Average life for a Xenon festoon lamp is 20,000 hours. LED festoon lamps are available in a 0.6 watt, 12VAC or 24 VAC models in several popular color temperatures. LED festoon lamps produce very little forward throw heat, no UV rays, and have an average lamp life of 40,000 hours. LED festoon lamps are perfect for retrofit applications or new projects that require a bright, efficient light source in hard to reach areas.

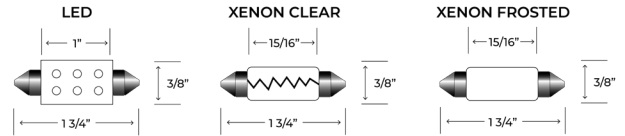

LED Kelvin Colors

2700 K 3500 K 5000 K

Xenon Kelvin Colors

2800K Clear 2800K Frost

Classic HM Series Transformers

TRANSFORMER SPECIFICATIONS

	20W	40W	60W	100W	150W	250W	500W
120/12VAC	MT20-12	MT40-12	MT60-12	MT100-12	MT150-12	MT250-12	MT500-12
120/24VAC	MT20-24	MT40-24	MT60-24	MT100-24	MT150-24	MT250-24	MT500-24
Max Wattage*	16	32	48	80	120	200	400
12V Breaker	Auto Reset	Auto Reset	Auto Reset	Auto Reset	Auto Reset	(1) 25A Push	(2) 25A Push
24V Breaker	Auto Reset	Auto Reset	Auto Reset	Auto Reset	Auto Reset	(1) 10A Push	(1) 25A Push
Height (H)	5.60"	5.60"	6.55"	6.55"	9.80"	6.75"	8.25"
Width (W)	2.10"	2.10"	2.55"	2.55"	3.00"	4.875"	5.62"
Depth (D)	2.10"	2.10"	2.55"	2.55"	3.00"	4.62"	5.25"
Weight (lbs)	2	2	3	7	7	13	19

*These numbers reflect the 20% safety factor that is recommended to avoid overload or nuisance tripping when selecting a transformer. (Wattage x 1.20)

To calculate amperage, divide total wattage by secondary voltage (Wattage/Voltage = Amperage).
To calculate wattage, divide amperage by secondary voltage (Amperage/Voltage = Wattage)

Phantom Classic Lighting Strips - Ordering Matrix
Sample Order Number: **HM-1-4-0.6-12-27-LL-12-FW-24**

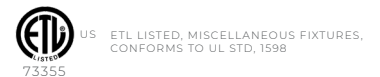

MODEL	TRIM PROFILE	LAMP SPACING	LAMP WATTAGE	OPERATING VOLTAGE	LAMP TYPE	LEAD TYPE*	LEAD LENGTH	TRIM COLOR	TRIM LENGTH
HM	1	4	0.6	12	27	LL	12"	FW	24"
HM	1	4"	0.6 - LED	12	27 - 2700K LED	LL - Leads Left	12"	FW - Flat White	Inches
	2	6"		24	35 - 3500K LED			GW - Gloss White	
	3	CS -	3 - Xenon		50 - 5000K LED	LR - Leads Right		FB - Flat Black	Specify
	4	Custom Spacing	5 - Xenon		XFR - Frost Xenon			GB - Gloss Black	Your Trim
			10 - Xenon		XCL - Clear Xenon			LB - Light Beige	Length In
						DL - Double Leads		MB - Medium Brown	Inches
								LA - Light Almond	
								UF - Unfinished	
								CC - Custom Color**	

*When facing application
**Contact factory for details