



Adjustable Concealed Shelf Lighting

Phantom™ Elite AC Series LED light strips are designed for fully adjustable shelf and cabinet linear lighting applications and represent a breakthrough in strip lighting technology due to proprietary wiring methods. Imagine having the ability to freely move your lighted shelves without rewiring, using only a phillips head screwdriver! These low profile cabinet lights are easily concealed regardless of the shelf design, giving new definition to the phrase, “See the Light, Not the Fixture.”

Custom mounting trims establish the optimum aiming angle which allows the contents of any cabinet to be illuminated to a precise degree at the highest level of aesthetics yet to be seen. Strips are precut to any desired length to be custom fitted to moveable shelves. There are no visible wires and shelf positions can be changed without any rewiring whatsoever. Strips are dimmable using a magnetic low voltage dimmer and produce a quality of consistent color and lumen output unmatched by competing products.

PHANTOM ELITE AC SERIES FEATURES

- Low profile, concealed linear LED lighting source designed for adjustable shelf lighting or adjustable display applications
- Exclusive current carrying design using concealed metal buss bars and brass mounting hardware
- Dimmable high-performance compact magnetic low-voltage 24VDC drivers (available in both 120V and 277V)



Elite AC Series Exploded View

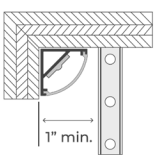

SPACE REQUIREMENT

For best results, a wood reveal should be used to conceal the fixture. For applications above eye level use a wood trim and extend as necessary. Allow 1" clearance between light fixture and buss bar.

LED LIGHTING STRIP

Each LED lighting strip is concealed by either a trim or a lensed enclosure. For best results, use a matte finish on the back of the cabinet to minimize reflections and/or glare.

BUSS BAR SUPPORTS (5/8" W X 1/4" D)

Heavy duty steel buss bars are concealed during construction and engineered to perfectly align with 8 x 32 threaded holes drilled 32 mm on center. This system totally hides all the wiring and allows you to use the drilled pin method of shelf support. Consult the factory for other spacing options.

DRIVER

Magnetic drivers are sized to match the total wattage of your lighting load and come equipped with one or more secondary circuit breakers. (See driver sheet for more sizing information and amperage calculations).

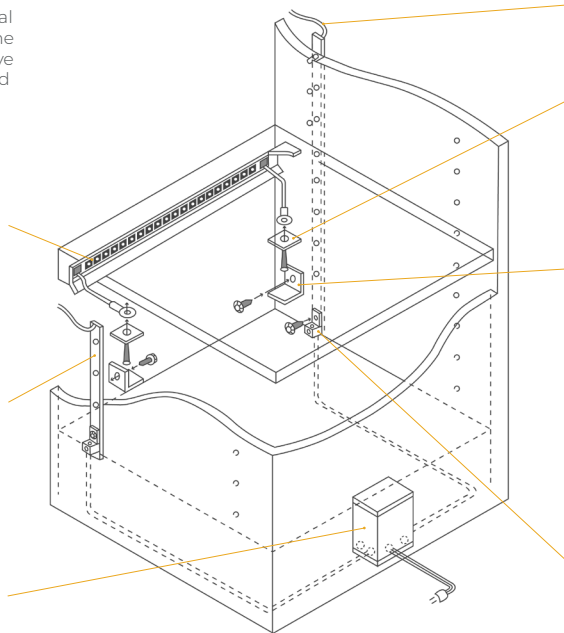

TOP HEADER LEAD WIRES (PAIR)

Always use the header kit to avoid exposed wires.

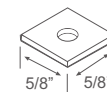

BRASS CONTACT PADS

Brass contact pads are designed to transfer electricity from the shelf support clip to the individual fixtures utilizing a safe low voltage current. Contact is made when the shelf is installed. No tools are required to rearrange the shelves!



BRASS SUPPORT CLIPS

Brass support clips are designed to transfer electricity from the concealed buss bar to the brass contact pad mounted on the bottom of the shelves utilizing a safe low voltage current.

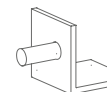

BACK OFFSET SHELF SUPPORT (BY OTHERS)

Standard right angle offset supports (1/4" or 3/16" pins) must be used to achieve a level shelf.

LUG CONNECTORS

Heavy duty lug connectors are used to connect the wire to the metal buss bars back to the power supply. These connections must remain accessible for service and maintenance. Orientation of lugs is dependent on your particular application.

SHIELDED

Trim Profiles

Shielded options are best for shaping the light in precise patterns and for minimizing both hot spots on surrounding surfaces and spill light that may stray outside the display. Available options include traditional diode tape and the latest chip-on-board (COB) tape that provides excellent light uniformity and seamless appearance.

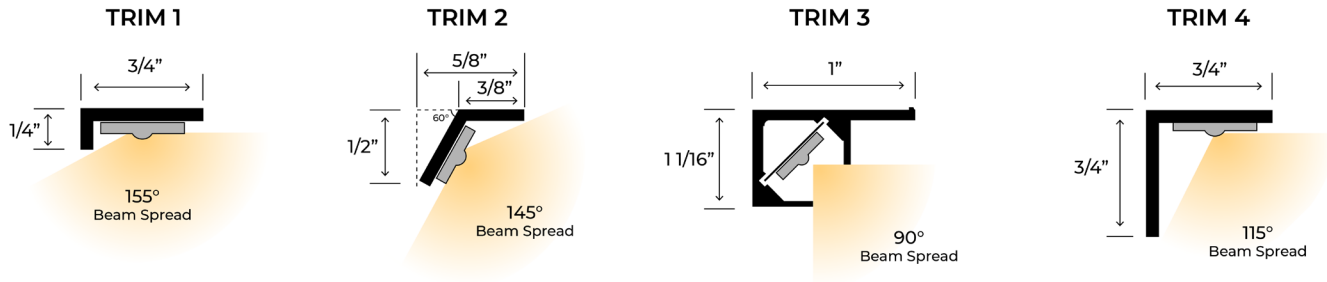

Our most popular shielded trims for this adjustable mounting method are trims 2 and 3. Both shielded trims are great for applications that have a shelf reveal as they provide the best light distribution and glare control. Trim 3 is perfect for shelves that have no reveal and can be installed and painted to match the cabinet color. For lensed trims, we recommend trim 9 for the ultimate in light distribution to conceal the LED diodes and provide total diffusion to prevent reflected glare from objects, reflective or gloss finishes. **See page 3 for lensed trim options.**

ELITE TAPE SPECIFICATIONS FOR SHIELDED TRIM PROFILES

24VDC LED Tape	Wattage	Kelvin Color	Lumens per Foot	Efficacy (LM/W)	CRI	Diodes per Foot	Cut Mark	Max Run Length
	2.2 Economy	1800K	142	64	94+	12	4.00 inches	45 feet
		2100K	161	73				
		2700K	178	81				
		3000K	187	85				
		3500K	194	88				
		4000K	196	89				
	2.7 COB Standard	1800K	210	78	92+	146	2.00 inches	35 feet
		2100K	248	92				
		2700K	262	97				
		3000K	274	100				
		3500K	286	106				
		4000K	292	108				

Phantom Elite Lighting Strips - Ordering Matrix
Sample Order Number: **AC-ES-1-18-2.2-AD-12-FW-XX**

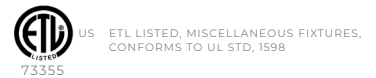

MODEL	SERIES TYPE	TRIM PROFILE	KELVIN COLOR	WATTS/FT	LEAD WIRES*	LEAD LENGTH	TRIM PAINT COLOR	TRIM LENGTH
AC	ES	1	18	2.2	AD	12	FW	XX
AC	ES - Elite Shielded	1 2 3 4	18 - 1800K 21 - 2100K 27 - 2700K 30 - 3000K 35 - 3500K 40 - 4000K	2.2 - 2.2W 2.7C - 2.7W	AD - Adjustable	12" 24" 36"	FW - Flat White GW - Gloss White FB - Flat Black GB - Gloss Black LB - Light Beige MB - Medium Brown LA - Light Almond UF - Unfinished CC - Custom Color**	Inches Specify Your Trim Length In Inches

*When facing application
**Contact factory for details

LENSED

Trim Profiles

Lensed options are the best for applications where the light fixture may be visible, by hiding the individual LED diodes and preventing object or surface reflections by homogenizing the light pattern.

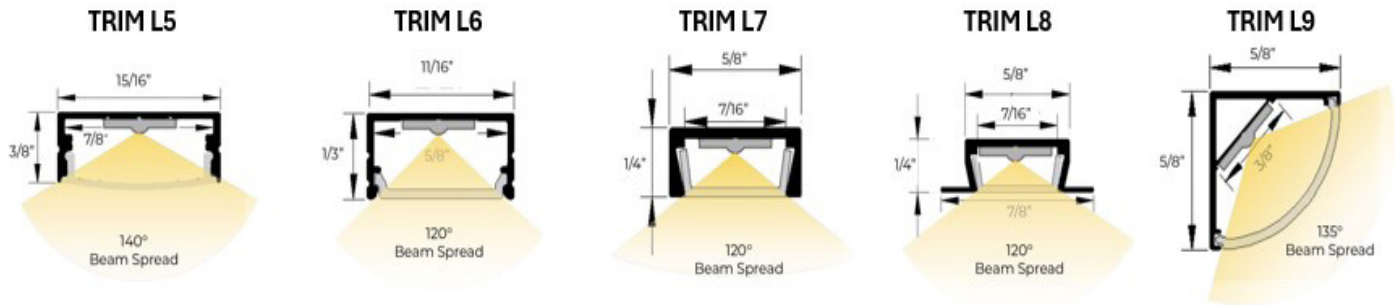

Additional Trim Profiles Available,
Please Contact Factory for Details

ELITE TAPE SPECIFICATIONS FOR LENSED TRIM PROFILES

24VDC LED Tape	Wattage	Kelvin Color	Lumens per Foot	Efficacy (LM/W)	CRI	Diodes per Foot	Cut Mark	Max Run Length
 15-SPEC-15-30 1.5 W/FT	1.5 High Density	1800K	129	86	94+	56	1.75 inches	60 feet
		2100K	154	102				
		2700K	179	119				
		3000K	191	127				
		3500K	195	130				
		4000K	197	131				
 15-SPEC-28-30 2.8 W/FT	2.8 High Density	1800K	235	83	94+	56	1.75 inches	35 feet
		2100K	246	87				
		2700K	273	97				
		3000K	298	106				
		3500K	319	113				
		4000K	303	108				
 DC24V LED-ES-3000-HCOB-27	2.7 COB Standard	1800K	210	78	92+	146	2.00 inches	35 feet
		2100K	248	92				
		2700K	262	97				
		3000K	274	100				
		3500K	286	106				
		4000K	292	108				

Phantom Elite Lighting Strips - Ordering Matrix
Sample Order Number: **AC-EL-5-18-2.8-AD-12-SA-XX**



ETL LISTED, MISCELLANEOUS FIXTURES,
CONFORMS TO UL STD, 1598

MODEL	SERIES TYPE	TRIM PROFILE	KELVIN COLOR	WATTS/FT	LEAD WIRES*	LEAD LENGTH	TRIM PAINT COLOR	TRIM LENGTH
AC	EL	5	18	2.8	AD	12	SA	XX
AC	EL - Elite Lensed	5 6 7 8 9 10	18 - 1800K 21 - 2100K 27 - 2700K 30 - 3000K 35 - 3500K 40 - 4000K	1.5 - 1.5W 2.8 - 2.8W 2.7C - 2.7W	AD - Adjustable	12" 24" 36"	SA - Satin Aluminum CC - Custom Color**	Inches Specify Your Trim Length In Inches

*When facing application
**Contact factory for details

MAGNETIC DRIVER SPECIFICATIONS

	20 VA	40 VA	60 VA	96 VA	150 VA	192 VA	200 VA	288VA	300 VA
120VAC/24VDC¹	MD20-24	MD40-24	MD60-24	MD96-24	MD150-24	MD192-24	MD200-24	MD288-24	MD300-24
Class	Class 2	Class 2	Class 2	Class 2	Class 1	Class 2 (2 ch)	Class 1	Class 2 (3 ch)	Class 1
Maximum Load*	20	40	60	96	150	192	200	288	300
Minimum Load	10	16	24	38	60	80	80	38	120
Circuit Breaker	Auto	Auto	Auto	Auto	Manual	Manual	Manual	Manual	Manual
Dimming	Yes - MLV	Yes - MLV	Yes - MLV	Yes - MLV	Yes - MLV	Yes - MLV	Yes - MLV	Yes - MLV	Yes - MLV
Height (H)	5.50"	5.50"	6.50"	6.50"	9.50"	9.50"	9.80"	9.50	9.80"
Width (W)	2.25"	2.25"	2.75"	2.75"	3.25"	3.25"	3.25"	3.25	4.25"
Depth (D)	2.00"	2.00"	2.25"	2.25"	4.00"	3.00"	3.00"	3.00	3.50"
Weight (lbs)	1.80	1.80	2.00	2.00	5.00	5.00	5.50	5.50	8.75

ELECTRONIC DRIVER SPECIFICATIONS

	60 VA	96 VA	96 VA	192 VA	288 VA
120VAC/24VDC¹	EDQ-LED24-MINI60	EDQ-LED24-MINI96	EDJ-LED24-96J	EDJ-LED24-192J	EDJ-LED24-288J
Class	Class 2	Class 2	Class 2	Class 2	Class 1
Maximum Load*	60	96	96	2x 96W (2 Channel)	3x 96W (3 Channel)
Minimum Load	15	40	24	30 per Channel	30 per Channel
Over Current	Protected	Protected	Protected	Protected	Protected
Dimming	Yes - ELV/MLV/Triac	Yes - ELV/MLV/Triac	Yes - ELV/MLV/Triac	Yes - ELV/MLV/Triac	Yes - ELV/MLV/Triac
Height (H)	2.9"	2.9"	4.75"	4.75"	4.75"
Width (W)	1.6"	1.6"	5.0"	7.4"	10.15"
Depth (D)	0.9"	0.9"	1.65"	1.65"	1.65"
Weight (lbs)	0.31	0.35	1.25	1.75	2.5

*DOES NOT reflect the 20% safety factor that is recommended to avoid overload or nuisance tripping when selecting a transformer. (Wattage x 1.20)
1 Available in 277VAC input, please contact factory for details

To calculate amperage, divide total wattage by secondary voltage (Wattage/Voltage = Amperage).
To calculate wattage, divide amperage by secondary voltage (Amperage/Voltage = Wattage)

Driver Dimensions

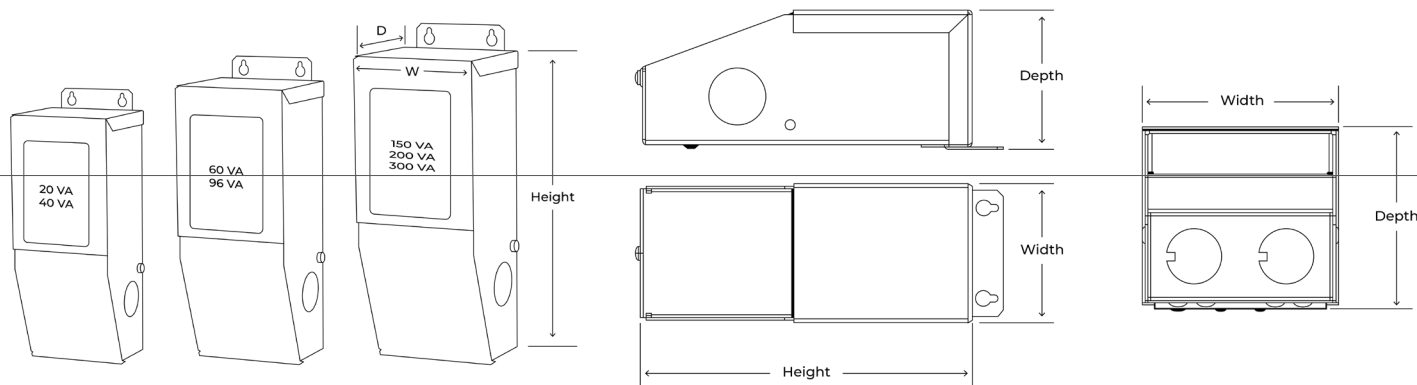

Elite AC Series Load Examples

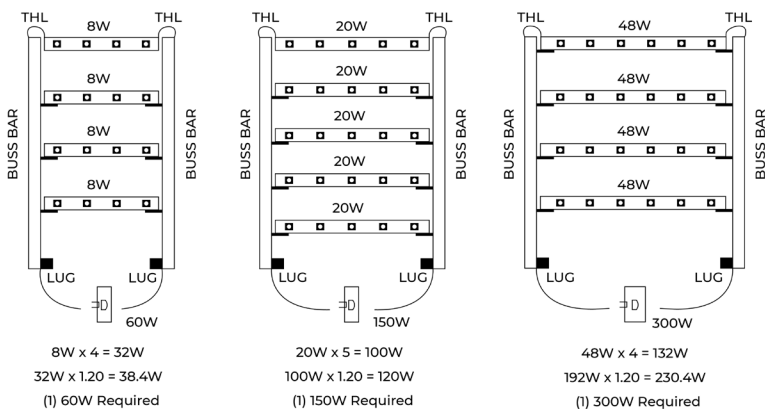

TERMS AND CONDITIONS

To comply with Phantom™ Lighting System warranty policies and ETL standards, all lighting strips must be used in conjunction with Phantom™ Lighting drivers. All Phantom lighting transformers are ETL Approved for Class 2 applications and are strongly recommended for proper orientation of lighting strips. Phantom™ drivers should **not** be located in areas without ventilation or be subjected to high ambient temperatures. If ambient temperatures exceed 115°F (46°C) around the driver, the circuit breakers may nuisance-trip due to excessive heat and void any warranty.

CAUTION: Failure to correctly size primary and secondary conductors and/or overload protection may result in bodily injury or serious property damage.

If you have any questions or concerns regarding your application, please contact the factory at (713) 863-1184 or consult a licensed electrician or the National Electric Code.