



# Task Lighting

**Phantom™ Elite TL Series** LED light strips are designed for any linear task or under-cabinet lighting application and represent a breakthrough in strip lighting technology. Perfect for kitchens, offices, desks, or counter tops, these low profile task lights are easily concealed regardless of the cabinet design, giving new definition to the phrase, “See the Light, Not the Fixture.”

Custom mounting trims establish the optimum aiming angle which allows the contents of any area to be illuminated to a precise degree at the highest level of aesthetics yet to be seen. Strips are precut to any desired length to be custom fitted for continuous under-cabinet lighting. Strips are dimmable using a magnetic low voltage dimmer and produce a quality of consistent color and lumen output unmatched by competing products.

## PHANTOM ELITE TL SERIES FEATURES

- Low profile, concealed linear LED lighting source designed for any under-cabinet lighting application
- Excellent assortment of power connectors, jumpers, and accessories for ease of installation
- Dimmable high-performance compact magnetic low-voltage 24VDC drivers (available in both 120V and 277V)



## Elite TL Series Exploded View

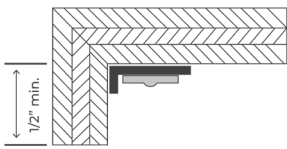

### LIGHTING STRIP LOCATION

For best results, always mount the lights behind the front lip of the upper cabinet and use a matte finish on the back of the cabinet or wall to minimize glare and reflections. Note: stone finishes, such as granite, marble, and ceramic tile are notorious for reflecting lamp images from normal viewing angles.

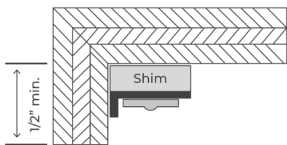

### LIGHTING STRIP TIP

It may be necessary, depending on the trim used, to field adjust lighting strips up or down with a shim to accommodate larger wood reveals and fine tune lighting coverage to the edge of the countertop.

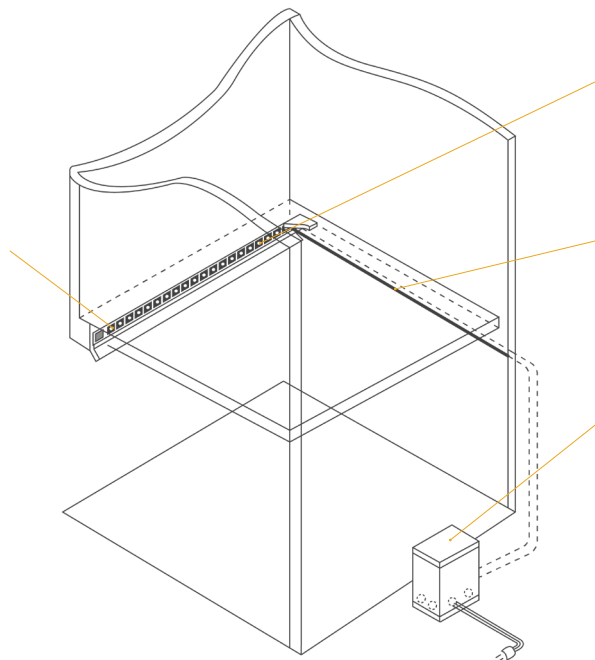

### LED LIGHTING STRIP

Each LED lighting strip is concealed by either a trim or a lensed enclosure. For best results, use a matte finish on the back of the cabinet to minimize reflections and/or glare.

### WIRE SLEEVE TIP

We recommend that you fabricate a small removable wood cover for the purpose of hiding the wires between the fixture and where the wire exits the wall. Most applications require an end feed connection.

### DRIVER (REMOTE MOUNT)

Magnetic drivers are sized to match the total wattage of your lighting load and come equipped with one or more secondary circuit breakers. (See driver sheet for more sizing information and amperage calculations).

### DIMMER CONTROLS (BY OTHERS)

Magnetic low voltage transformers should always be used with a dimmer designated for magnetic or inductive loads. Electronic transformers should always be used with a dimmer designated for electronic loads.

# SHIELDED

## Trim Profiles

Shielded options are best for shaping the light in precise patterns and for minimizing both hot spots on surrounding surfaces and spill light that may stray outside the display. Available options include traditional diode tape and the latest chip-on-board (COB) tape that provides excellent light uniformity and seamless appearance.

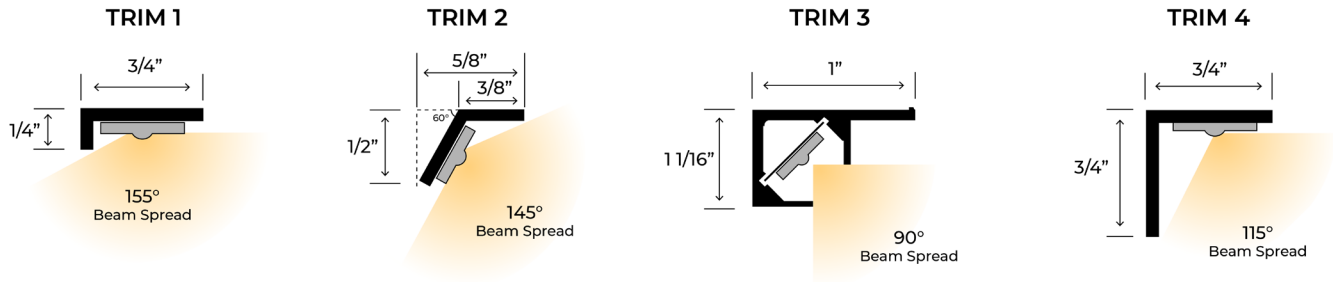

Our most popular shielded trims for under cabinet task lighting are trims 1 and 2. Both shielded trims are great for applications that have a under cabinet reveal as they provide the best light distribution and glare control. Trim 3 is perfect for cabinets that have no reveal and can be installed and painted to match the cabinet color. For lensed trims, we recommend trim 6 and 9 for the ultimate in light distribution to hide the LED diodes and provide total diffusion to prevent reflected glare from tile, granite, marble, stainless steel or gloss finishes. **See page 3 for lensed trim options.**

### ELITE TAPE SPECIFICATIONS FOR SHIELDED TRIM PROFILES

24VDC LED Tape	Wattage	Kelvin Color	Lumens per Foot	Efficacy (LM/W)	CRI	Diodes per Foot	Cut Mark	Max Run Length
	2.2 Economy	1800K	142	64	94+	12	4.00 inches	45 feet
		2100K	161	73				
		2700K	178	81				
		3000K	187	85				
		3500K	194	88				
	2.7 COB Standard	1800K	210	78	92+	146	2.00 inches	35 feet
		2100K	248	92				
		2700K	262	97				
		3000K	274	100				
		3500K	286	106				
		4000K	292	108				

Phantom Elite Lighting Strips - Ordering Matrix  
Sample Order Number: **TL-ES-1-18-2.2-DL-12-FW-XX**



ETL LISTED, MISCELLANEOUS FIXTURES, CONFORMS TO UL STD, 1598

MODEL	SERIES TYPE	TRIM PROFILE	KELVIN COLOR	WATTS/FT	LEAD WIRES*	LEAD LENGTH	TRIM PAINT COLOR	TRIM LENGTH
TL	ES	1	18	2.2	DL	12	FW	XX
TL	ES - Elite Shielded	1 2 3 4	18 - 1800K 21 - 2100K 27 - 2700K 30 - 3000K 35 - 3500K 40 - 4000K	1.8 - 1.8W 2.2 - 2.2W	DL - Double Leads LR - Leads Left LL - Leads Left	12" 24" 36" 48" 120" 300"	FW - Flat White GW - Gloss White FB - Flat Black GB - Gloss Black LB - Light Beige MB - Medium Brown LA - Light Almond UF - Unfinished CC - Custom Color**	Inches  Specify Your Trim Length In Inches

\*When facing application  
\*\*Contact factory for details

# LENSED

## Trim Profiles

Lensed options are the best for applications where the light fixture may be visible, by hiding the individual LED diodes and preventing object or surface reflections by homogenizing the light pattern.

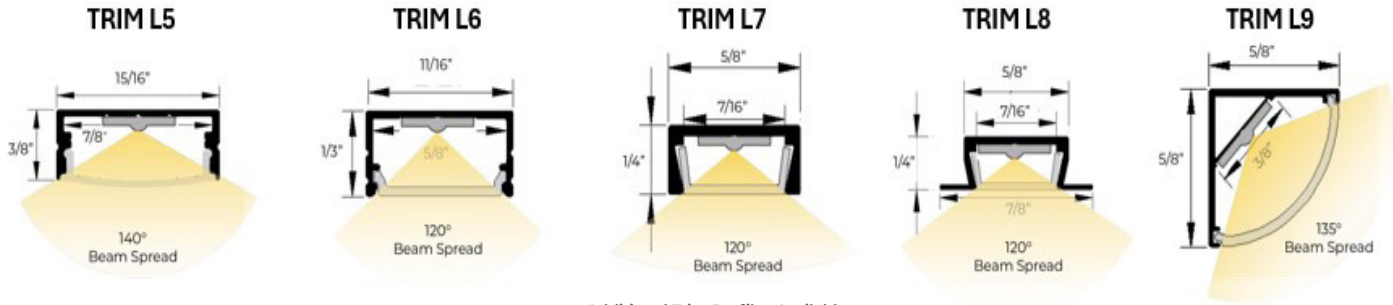

Additional Trim Profiles Available,  
Please Contact Factory for Details

### ELITE TAPE SPECIFICATIONS FOR LENSED TRIM PROFILES

24VDC LED Tape	Wattage	Kelvin Color	Lumens per Foot	Efficacy (LM/W)	CRI	Diodes per Foot	Cut Mark	Max Run Length
 15-SPEC-15-30 24VDC + 1.5 W/FT -	1.5 High Density	1800K	129	86	94+	56	1.75 inches	60 feet
		2100K	154	102				
		2700K	179	119				
		3000K	191	127				
		3500K	195	130				
		4000K	197	131				
 15-SPEC-28-30 24VDC + 2.8 W/FT -	2.8 High Density	1800K	235	83	94+	56	1.75 inches	35 feet
		2100K	246	87				
		2700K	273	97				
		3000K	298	106				
		3500K	319	113				
		4000K	303	108				
 DC24V LED-ES-3000-HCOB-27 + -	2.7 COB Standard	1800K	210	78	92+	146	2.00 inches	35 feet
		2100K	248	92				
		2700K	262	97				
		3000K	274	100				
		3500K	286	106				
		4000K	292	108				

Phantom Elite Lighting Strips - Ordering Matrix  
Sample Order Number: **AC-EL-5-18-2.8-AD-12-SA-XX**



ETL LISTED, MISCELLANEOUS FIXTURES,  
CONFORMS TO UL STD, 1598

MODEL	SERIES TYPE	TRIM PROFILE	KELVIN COLOR	WATTS/FT	LEAD WIRES*	LEAD LENGTH	TRIM PAINT COLOR	TRIM LENGTH
AC	EL	5	18	2.8	AD	12	SA	XX
AC	EL - Elite Lensed	5 6 7 8 9 10	18 - 1800K 21 - 2100K 27 - 2700K 30 - 3000K 35 - 3500K 40 - 4000K	1.5 - 1.5W 2.8 - 2.8W 2.7C - 2.7W	AD - Adjustable	12" 24" 36"	SA - Satin Aluminum CC - Custom Color**	Inches  Specify Your Trim Length In Inches

\*When facing application  
\*\*Contact factory for details

MAGNETIC DRIVER SPECIFICATIONS									
	20 VA	40 VA	60 VA	96 VA	150 VA	192 VA	200 VA	288VA	300 VA
<b>120VAC/24VDC<sup>1</sup></b>	MD20-24	MD40-24	MD60-24	MD96-24	MD150-24	MD192-24	MD200-24	MD288-24	MD300-24
<b>Class</b>	Class 2	Class 2	Class 2	Class 2	Class 1	Class 2 (2 ch)	Class 1	Class 2 (3 ch)	Class 1
<b>Maximum Load*</b>	20	40	60	96	150	192	200	288	300
<b>Minimum Load</b>	10	16	24	38	60	80	80	38	120
<b>Circuit Breaker</b>	Auto	Auto	Auto	Auto	Manual	Manual	Manual	Manual	Manual
<b>Dimming</b>	Yes - MLV	Yes - MLV	Yes - MLV	Yes - MLV	Yes - MLV	Yes - MLV	Yes - MLV	Yes - MLV	Yes - MLV
<b>Height (H)</b>	5.50"	5.50"	6.50"	6.50"	9.50"	9.50"	9.80"	9.50	9.80"
<b>Width (W)</b>	2.25"	2.25"	2.75"	2.75"	3.25"	3.25"	3.25"	3.25	4.25"
<b>Depth (D)</b>	2.00"	2.00"	2.25"	2.25"	4.00"	3.00"	3.00"	3.00	3.50"
<b>Weight (lbs)</b>	1.80	1.80	2.00	2.00	5.00	5.00	5.50	5.50	8.75

ELECTRONIC DRIVER SPECIFICATIONS					
	60 VA	96 VA	96 VA	192 VA	288 VA
<b>120VAC/24VDC<sup>1</sup></b>	EDQ-LED24-MINI60	EDQ-LED24-MINI96	EDJ-LED24-96J	EDJ-LED24-192J	EDJ-LED24-288J
<b>Class</b>	Class 2	Class 2	Class 2	Class 2	Class 1
<b>Maximum Load*</b>	60	96	96	2x 96W (2 Channel)	3x 96W (3 Channel)
<b>Minimum Load</b>	15	40	24	30 per Channel	30 per Channel
<b>Over Current</b>	Protected	Protected	Protected	Protected	Protected
<b>Dimming</b>	Yes - ELV/MLV/Triac	Yes - ELV/MLV/Triac	Yes - ELV/MLV/Triac	Yes - ELV/MLV/Triac	Yes - ELV/MLV/Triac
<b>Height (H)</b>	2.9"	2.9"	4.75"	4.75"	4.75"
<b>Width (W)</b>	1.6"	1.6"	5.0"	7.4"	10.15"
<b>Depth (D)</b>	0.9"	0.9"	1.65"	1.65"	1.65"
<b>Weight (lbs)</b>	0.31	0.35	1.25	1.75	2.5

\*DOES NOT reflect the 20% safety factor that is recommended to avoid overload or nuisance tripping when selecting a transformer. (Wattage x 1.20)  
 To calculate amperage, divide total wattage by secondary voltage (Wattage/Voltage = Amperage).  
 To calculate wattage, divide amperage by secondary voltage (Amperage/Voltage = Wattage)  
 1 Available in 277VAC input, please contact factory for details

### Driver Dimensions

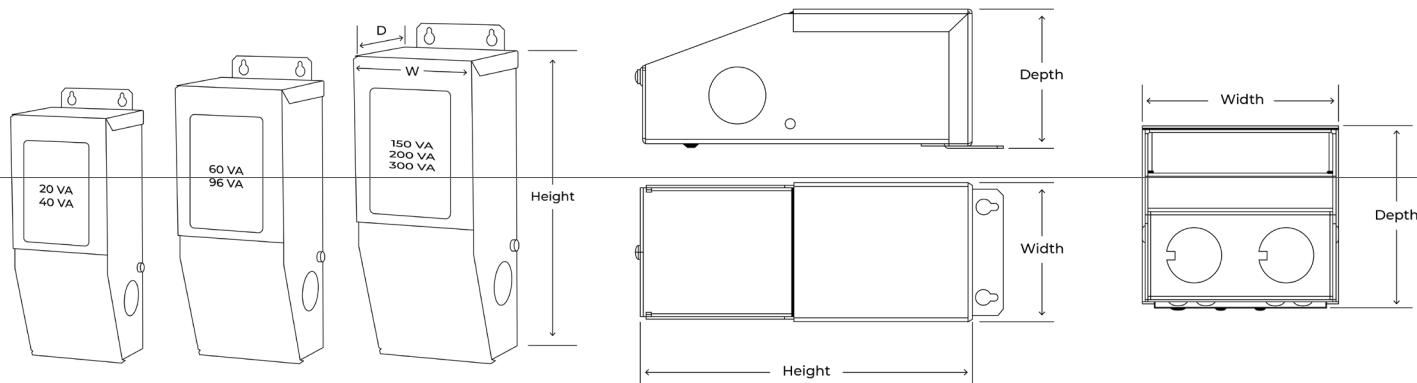

### Elite TL Series Load Examples

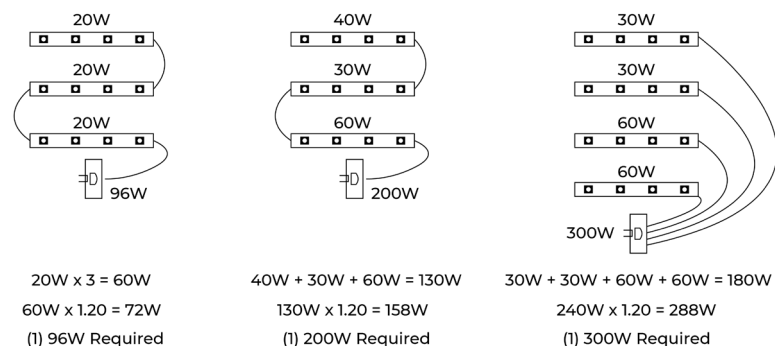

### TERMS AND CONDITIONS

To comply with Phantom™ Lighting System warranty policies and ETL standards, all lighting strips must be used in conjunction with Phantom™ Lighting drivers. All Phantom lighting transformers are ETL Approved for Class 2 applications and are strongly recommended for proper orientation of lighting strips. Phantom™ drivers should **not** be located in areas without ventilation or be subjected to high ambient temperatures. If ambient temperatures exceed 115°F (46°C) around the driver, the circuit breakers may nuisance-trip due to excessive heat and void any warranty.

**CAUTION:** Failure to correctly size primary and secondary conductors and/or overload protection may result in bodily injury or serious property damage.

If you have any questions or concerns regarding your application, please contact the factory at (713) 863-1184 or consult a licensed electrician or the National Electric Code.