



ART LIGHTING

CONTOUR  
PROJECTORS



LED

# Top Access LED Projector

**Phantom™ Top Access Mount Projector** is an optical framing projector with remodeler IC-Rated housing, designed for custom installations only.

When it comes to professional lighting art, nothing is more impressive or visually effective than an optical framing projector. A hidden light source with a controlled beam of light precisely illuminates the canvas. Phantom Contour Projectors are designed by a professional installer and have been engineered so that anyone can complete the install. The options we offer make this LED projector one of the most versatile and best art lighting fixtures on the market today.



**ETL LISTED**

Conforms to UL STD 1598 Requirements  
Certified to CSA STD C22.2 NO.250.0



## ABOVE

This painting was displayed in a hallway with a plaster barrel-vault ceiling that required the use of a Phantom™ Top Access LED projector. With only a small penetration in the ceiling, the projector was aimed and adjusted using a hand-cut template to shape the light. These types of installations are completely custom and it is recommended that the installer have prior experience hand-cutting templates and installations using the Wendel technique.

## LEFT

Another example of an installation using a Phantom™ Top Access LED projector, again with a hand-cut template. The exposed brass shield covering the focal cone was eventually painted to seamlessly match the ceiling for a more discreet and modern look.

## Masking Method

There are two masking methods available for this model of the LED Contour Projector: custom-cut brass templates for single, multiple or irregularly shaped artworks, and stainless steel gobos (Rosco® Type M) for patterned lighting effects. Adjustable shutters are not available for the TAL model.

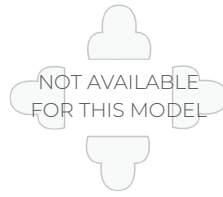

ALUMINUM SHUTTERS



BRASS TEMPLATE



STAINLESS STEEL GOBO

## Projector Details

High performance optical framing projector with variable optics system consisting of two (2) 39mm focal lenses and two (2) 60mm condensing lenses designed for both long and short throws as well as off center mounting. The special Achromatic focal lenses produce crisp sharp lines without any chromatic abnormalities.

### LIGHT SOURCE

PHANTOM™ Gen4 Proprietary LED light engine with a custom concentric parabolic reflector, aluminum heat sink, active DC cooling fan and the CREE® XLamp Extreme High Power XHP 3000K LED with 90+ CRI and average lamp life of 30,000 hours.

Total Load is 30W.

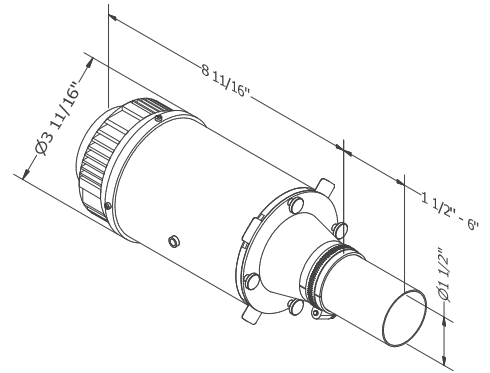

## TAL Housing Dimensions

Low profile IC-rated housing designed for installation by experienced installers who require no access from below and prefer cutting brass templates. The square housing comes with bottom heat shield and fixture bars designed for any rafter spacing up to 24" and will fit in 2" x 10" framing. A small oval trim ring with mounting tabs and adjustable glare shield is provided to conceal ceiling penetration and hiding the light source.

### ELECTRICAL SPECS

Includes auto-sensing 120-277V, 50/60Hz, 1750mA constant current electronic LED driver, Tri-Dimming (MLV forward phase, ELV reverse phase, 0-10V) and a non-dimming 12VDC fan power supply. Optional on-board 0-10V dimmer control available for setting output levels.

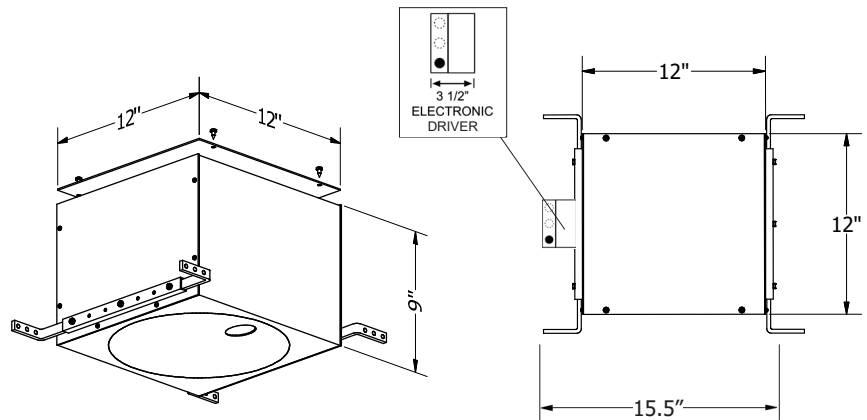

Phantom LED Contour Projectors - Ordering Matrix  
Sample Order Number: **TAL-2-1-0-1-U**

HOUSING	MASKING	LENS COMBINATION	ACCESSORY OPTIONS	COVER PLATE	COLOR
<b>TAL</b>	<b>2</b>	<b>1</b>	<b>0</b>	<b>1</b>	<b>U</b>
TAL	2 - Template 3 - Gobo	1 - Achromatic 75fl Lenses (Wide Flood Lenses)  2 - Achromatic 100fl Lenses (Flood Light Lenses)  3 - Achromatic 150fl Lenses (Narrow Spot Lenses)	0 - None 1 - 2700K Dichroic Filter 2 - 3500K Dichroic Filter 3 - 4000K Dichroic Filter 4 - On-board 0-10V Dimmer	1 - Slotted Trim Ring	U - Unfinished
<p><b>Standard Configuration</b> includes recessed top-access housing, an unfinished trim ring with glare shield, 120-277V auto-sensing LED/Fan drivers, optical framing projector with 39mm 75fl focal lenses and template masking set.</p>					

# Determining the Location of Projector in Ceiling

Example: Let's say you have a painting that is 36" High x 24" Wide and it is down from the ceiling roughly 20" to top of canvas. Doing the math, you get  $20" + 12" + 4" = 36"$  out from the wall to the front of the housing as a starting point. The projector can be moved back, left or right as needed to avoid obstructions in the ceiling or to address reflective glare and frame shadows.

An oversized painting can be accommodated in the same way by using two (2) Contour Projectors, mounted at oblique angles. Complimentary design assistance is available from the factory.

## VERTICAL TARGET

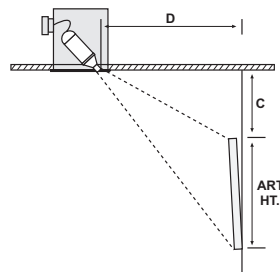

SLOTTED COVER PLATE (STANDARD)

## HORIZONTAL TARGET

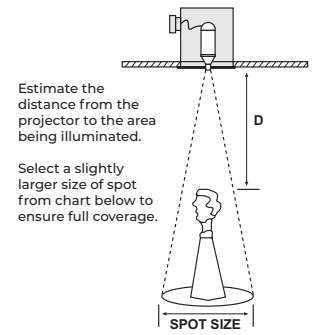

PIN HOLE COVER PLATE (OPTIONAL)

## CALCULATING THROW DISTANCE:

$$C + 1/3 \text{ of art height} + 4 = D$$

C = Distance down from ceiling to top of the art  
 D = Distance out from wall where projector mounts  
 (See first illustration to the right)

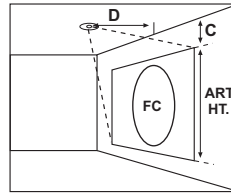

Formula Illustration

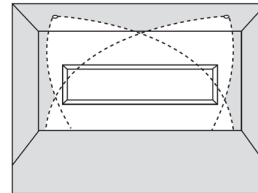

Overlapping Beam Diagram

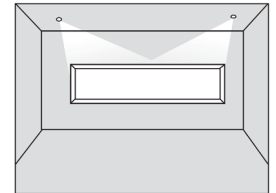

Oversize Beam Spread Result

# Achromatic Focal Lens Performance Chart

## DATA FOR THE PHANTOM GENERATION 4 LIGHT ENGINE

THROW DISTANCE (IN FEET)			1'		2'		3'		4'		5'	
Beam Spread	Lens Combo	Beam Angle	Spot Size	Foot Candles	Spot Size	Foot Candles	Spot Size	Foot Candles	Spot Size	Foot Candles	Spot Size	Foot Candles
Wide Flood Lens	75/75	60°	14"	1010	28"	585	42"	194	55"	94	69"	57
Flood Light	100/100	48°	11"	1185	21"	1011	32"	375	43"	183	53"	107
Narrow Spot	150/150	28°	6"	3285	12"	2035	18"	911	24"	431	30"	246
THROW DISTANCE (IN FEET)			6'		7'		8'		9'		10'	
Beam Spread	Lens Combo	Beam Angle	Spot Size	Foot Candles	Spot Size	Foot Candles	Spot Size	Foot Candles	Spot Size	Foot Candles	Spot Size	Foot Candles
Wide Flood Lens	75/75	60°	83"	41	97"	29	111"	23	125"	16	139"	12
Flood Light	100/100	48°	64"	71	75"	54	85"	41	96"	31	107"	26
Narrow Spot	150/150	28°	36"	166	42"	127	48"	88	54"	67	60"	55
THROW DISTANCE (IN FEET)			11'		12'		13'		14'		15'	
Beam Spread	Lens Combo	Beam Angle	Spot Size	Foot Candles	Spot Size	Foot Candles	Spot Size	Foot Candles	Spot Size	Foot Candles	Spot Size	Foot Candles
Wide Flood Lens	75/75	60°	-	-	-	-	-	-	-	-	-	-
Flood Light	100/100	48°	118"	21	128"	17	139"	14	150"	11	160"	9
Narrow Spot	150/150	28°	66"	44	72"	39	78"	33	84"	29	90"	23
THROW DISTANCE (IN FEET)			16'		17'		18'		19'		20'	
Beam Spread	Lens Combo	Beam Angle	Spot Size	Foot Candles	Spot Size	Foot Candles	Spot Size	Foot Candles	Spot Size	Foot Candles	Spot Size	Foot Candles
Wide Flood Lens	75/75	60°	-	-	-	-	-	-	-	-	-	-
Flood Light	100/100	48°	-	-	-	-	-	-	-	-	-	-
Narrow Spot	150/150	28°	98"	21	102"	19	108"	17	114"	15	120"	13