

Cove Mount Lighting

Phantom™ Classic CM Series light strips provide the ultimate performance and flexibility as a seamless, concealed low voltage linear lighting source. All Phantom CM Series lighting strips are manufactured to your exact specifications using a variety of custom metal glare shields, so that the light is always perfectly controlled while keeping the fixture out of sight. Lamping options include 3 watt, 5 watt, and 10 watt Xenon festoon lamps (rated for up to 20,000 hours) and LED lamps (rated for up to 40,000 hours). Energy-efficient 0.6 watt 12VAC LED lamps are ideal for applications where energy code compliance is an issue or a major consideration.

All lamping options are fully dimmable for achieving the perfect light level or to extend lamp life. Phantom CM series light strips are available unfinished or in eight painted colors. Please contact the factory if you're interested in our custom color options. Phantom Lighting is all about seeing the light, not the fixture.

PHANTOM CLASSIC CM SERIES FEATURES

- Low profile, concealed linear lighting source for new construction or retrofit architectural lighting applications
- Paint grip galvanized metal trim with unique glare shields specifically designed for coves or indirect lighting applications
- May be field cut or notched for radius cove light applications
- Continuous feed-through capacity, with up to 13.33 amps per fixture
- LED and Xenon festoon lamping options
- ETL Listed, Miscellaneous fixtures, conforms to UL STD, 1598

Classic CM Series Exploded View

LIGHTING STRIP

Each lighting strip may contain one or more festoon lamps with spacing 4 or 6 inches on center. For best results, always use a matte finish on the back of the cabinet to minimize reflections or glare.

RADIUS INSTALLATION

Phantom trim may be field cut or notched to achieve a radius or irregular shape.

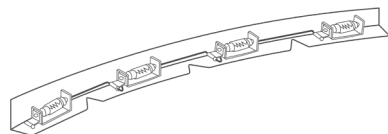

TRANSFORMER

Magnetic transformers are sized to match the total wattage of your lighting load and come equipped with one or more secondary circuit breakers. (See driver sheet for more sizing information and amperage calculations).

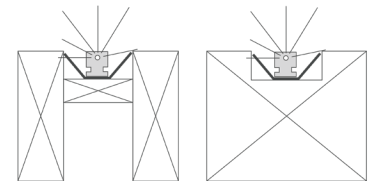
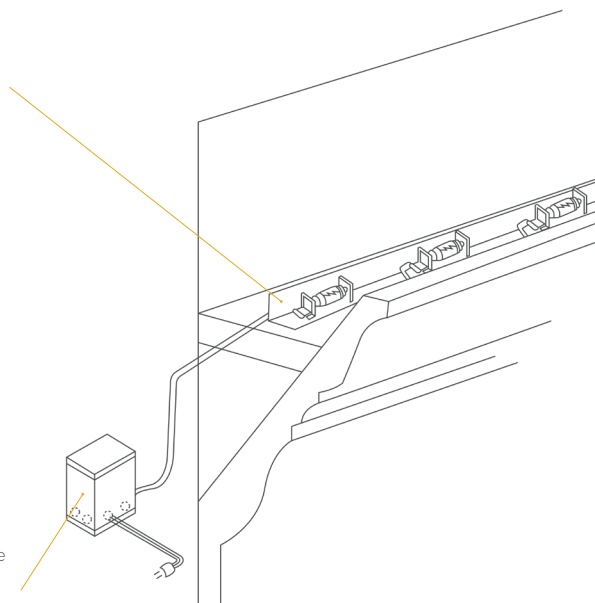

BEAM/TRUSS APPLICATION

Phantom lighting strips may be installed in exposed beams or trusses by using trim #5 for indirect lighting applications. Wood strips can be added between trusses to support the lighting strips or they may be routed directly into the tops of beams.

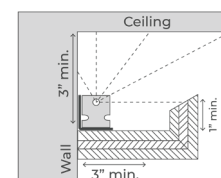

SPACE REQUIREMENT

On a cabinet with adjustable shelves, 1" of clearance is required between the back surface of the stile and the front of the shelf. This will provide the space to move shelves without modifying the Phantom fixture.

Classic CM Series Trim Profiles

Phantom offers a variety of trim profiles to suit any lighting application. Choose your trim profile based on your mounting application and the level of glare desired.

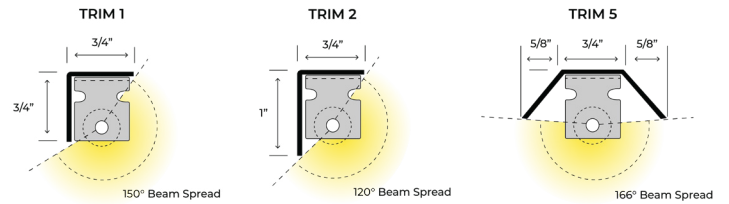

Classic CM Series Lamps

Xenon festoon lamps are available in 3 watt, 5 watt, and 10 watt, in both 12VAC and 24VAC. Xenon lamps (2,800°K) typically produce a whiter light and are used for display lighting. Average life for a Xenon festoon lamp is 20,000 hours. LED festoon lamps are available in a 0.6 watt, 12VAC or 24 VAC models in several popular color temperatures. LED festoon lamps produce very little forward throw heat, no UV rays, and have an average lamp life of 40,000 hours. LED festoon lamps are perfect for retrofit applications or new projects that require a bright, efficient light source in hard to reach areas.

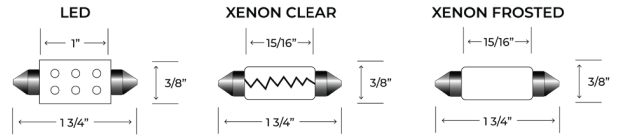

LED Kelvin Colors

- 2700 K
- 3500 K
- 5000 K

Xenon Kelvin Colors

- 2800K Clear
- 2800K Frost

Classic CM Series Transformers

TRANSFORMER SPECIFICATIONS

	20W	40W	60W	100W	150W	250W	500W
120/12VAC	MT20-12	MT40-12	MT60-12	MT100-12	MT150-12	MT250-12	MT500-12
120/24VAC	MT20-24	MT40-24	MT60-24	MT100-24	MT150-24	MT250-24	MT500-24
Max Wattage*	16	32	48	80	120	200	400
12V Breaker	Auto Reset	Auto Reset	Auto Reset	Auto Reset	Auto Reset	(1) 25A Push	(2) 25A Push
24V Breaker	Auto Reset	Auto Reset	Auto Reset	Auto Reset	Auto Reset	(1) 10A Push	(1) 25A Push
Height (H)	5.60"	5.60"	6.55"	6.55"	9.80"	6.75"	8.25"
Width (W)	2.10"	2.10"	2.55"	2.55"	3.00"	4.875"	5.62"
Depth (D)	2.10"	2.10"	2.55"	2.55"	3.00"	4.62"	5.25"

*These numbers reflect the 20% safety factor that is recommended to avoid overload and nuisance tripping when selecting a transformer. (Wattage x 1.20)

To calculate amperage, divide total wattage by secondary voltage (Wattage/Voltage = Amperage).
To calculate wattage, divide amperage by secondary voltage (Amperage/Voltage = Wattage)

Phantom Classic Lighting Strips - Ordering Matrix
Sample Order Number: **CM-1-4-0.6-12-27-DL-12-FW-24**

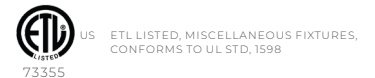

MODEL	TRIM PROFILE	LAMP SPACING	LAMP WATTAGE	OPERATING VOLTAGE	LAMP TYPE	LEAD TYPE	LEAD LENGTH	TRIM COLOR	TRIM LENGTH
CM	1	4	0.6	12	27	DL	12"	FW	24"
CM	1	4"	0.6 - LED	12	27 - 2700K LED	DL	12"	FW - Flat White	GW -
	2	6"		24	35 - 3500K LED	Double Leads	18"	Gloss White	FB - Flat
	5	CS - Custom Spacing	3 - Xenon		50 - 5000K LED		24"	Black	GB - Gloss
			5 - Xenon				36"	Black	LB - Light
			10 - Xenon		XFR - Frost Xenon		CUSTOM	Beige	MB - Medium
					XCL - Clear Xenon			Brown	LA - Light
								Almond	UF - Unfinished
								Color	CC - Custom Color

*Specify Your Trim Length In Inches

*Contact factory for details