



CABINET LIGHTING

ALL SERIES



CLASSIC LEVEL

Magnetic Transformers

TRANSFORMER SPECIFICATIONS

	SMALL FORMAT		MEDIUM FORMAT		LARGE FORMAT		
	20W	40W	60W	100W	150W	250W	500W
120/12VAC	MT20-12	MT40-12	MT60-12	MT100-12	MT150-12	MT250-12	MT500-12
120/24VAC	MT20-24	MT40-24	MT60-24	MT100-24	MT150-24	MT250-24	MT500-24
Max Wattage*	16	32	48	80	120	200	400
12V Breaker	Auto Reset	Auto Reset	Auto Reset	Auto Reset	Auto Reset	(1) 25A Push	(2) 25A Push
24V Breaker	Auto Reset	Auto Reset	Auto Reset	Auto Reset	Auto Reset	(1) 10A Push	(1) 25A Push
Height (H)	5.60"	5.60"	6.55"	6.55"	9.80"	6.75"	8.25"
Width (W)	2.10"	2.10"	2.55"	2.55"	3.00"	4.875"	5.62"
Depth (D)	2.10"	2.10"	2.55"	2.55"	3.00"	4.62"	5.25"

*These numbers reflect the 20% safety factor that is recommended to avoid overload or nuisance tripping when selecting a transformer. (Wattage x 1.20)

To calculate amperage, divide total wattage by secondary voltage (Wattage/Voltage = Amperage)
To calculate wattage, divide amperage by secondary voltage (Amperage/Voltage = Wattage)

Transformer Dimensions

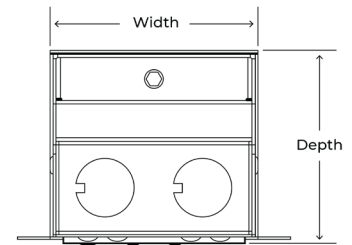
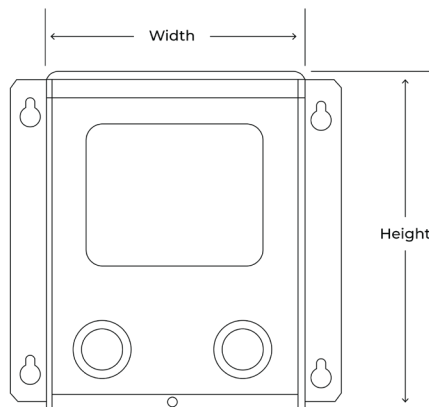
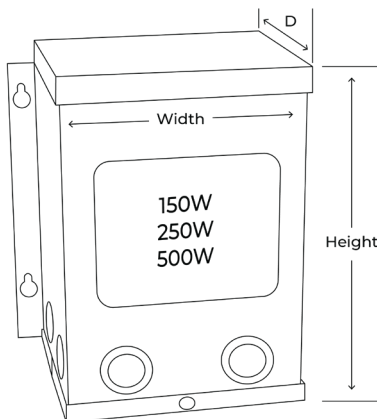
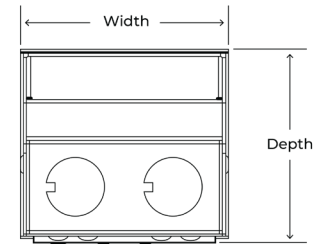
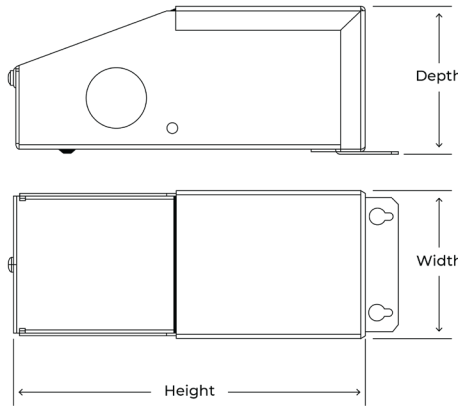
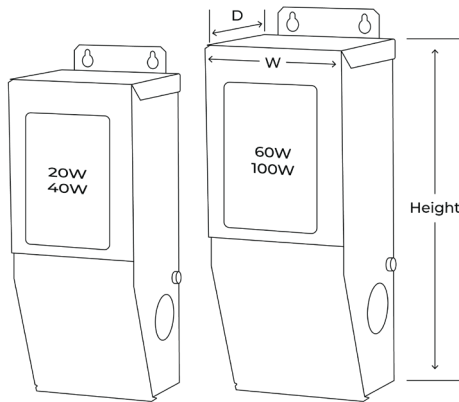

Secondary Wiring Diagrams Small/Medium Format

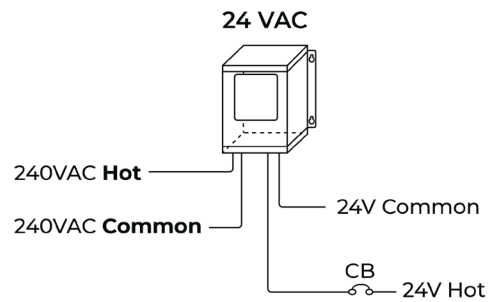
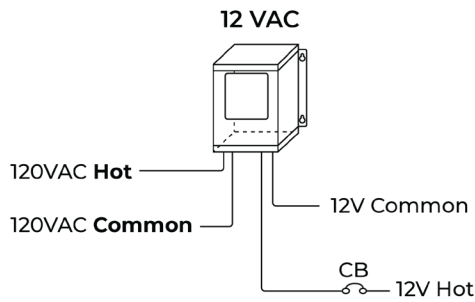

Large Format

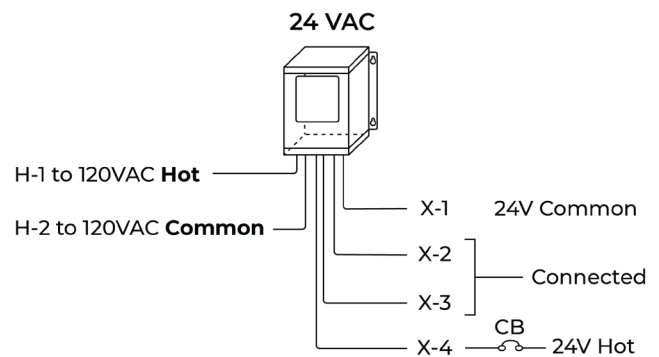
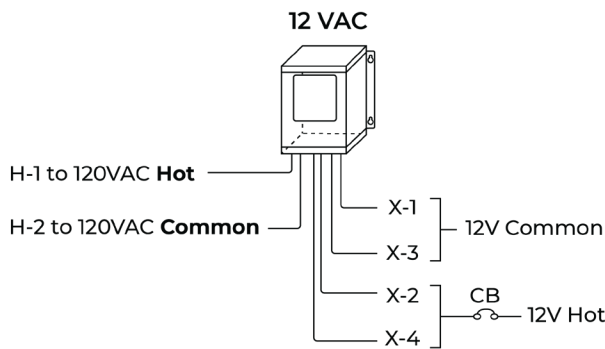

Secondary Wiring Examples

Just because you are installing a low voltage system, it doesn't mean that you can use low voltage wire! In fact, low voltage current operates at higher amperage levels than standard 120 volt systems. The current is 10 times greater for a 12 volt system than for a 120 volt system of the same wattage. Consequently, you must use larger wire sizes for 12 and 24 volt systems to minimize voltage drop and to handle the amperage loads. It is always best to locate your transformer adjacent to the lights, in the center of the run or as short a distance as possible to maintain lumen output. When at all possible, voltage drop should be limited to 5% loss between the transformer and the lighting strips.

Small Format

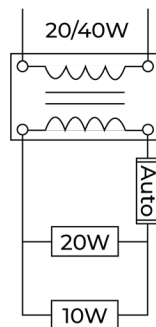

Medium Format

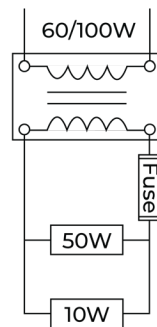

Large Format

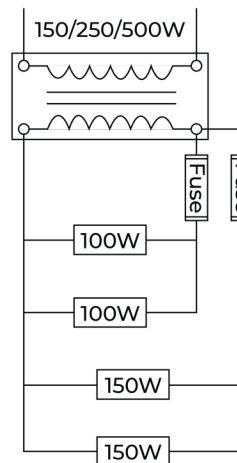

Classic Series Transformer Wattage/Voltage Chart

WARNING: There is a limit on how many Phantom fixtures can be connected in tandem. No circuit shall exceed 16 watts on 12V and 320 watts on 24V. Maximum feed through capacity shall not exceed 13.33 amps.

		LAMP TYPE / WATTAGE AND VOLTAGE													
		1.8W / 12V LED					1.8W / 24V LED					8'	9'	10'	
4"	1.8W / 12V LED	Wattage	1.8	3.6	5.4	7.2	9.0	10.8	12.6	14.4	16.2	18.0			
		Amperage	0.15	0.30	0.45	0.60	0.75	0.90	1.05	1.20	1.35	1.50			
6"	1.8W / 24V LED	Wattage	1.8	3.6	5.4	7.2	9.0	10.8	12.6	14.4	16.2	18.0			
		Amperage	0.08	0.15	0.23	0.30	0.37	0.45	0.52	0.60	0.67	0.75			
4"	3W / 12V XENON	Wattage	9	18	27	36	45	54	63	72	81	90			
		Amperage	0.75	1.50	2.25	3.00	3.75	4.50	5.25	6.00	6.75	7.50			
4"	3W / 24V XENON	Wattage	9	18	27	36	45	54	63	72	81	90			
		Amperage	0.38	0.75	1.13	1.50	1.88	2.25	2.63	3.00	3.38	3.75			
4"	5W / 12V XENON	Wattage	15	30	45	60	75	90	105	120	135	150			
		Amperage	1.25	2.50	3.75	5.00	6.25	7.50	8.75	10.00	11.25	12.50			
4"	5W / 24V XENON	Wattage	15	30	45	60	75	90	105	120	135	150			
		Amperage	0.63	1.25	1.88	2.50	3.13	3.75	4.38	5.00	5.63	6.25			
4"	10W / 12V XENON	Wattage	30	60	90	120	150	-	-	-	-	-			
		Amperage	2.50	5.00	7.50	10.00	12.50	-	-	-	-	-			
4"	10W / 24V XENON	Wattage	30	60	90	120	150	180	210	240	270	300			
		Amperage	1.25	2.50	3.75	5.00	6.25	7.50	8.75	10.00	11.25	12.50			

Terms and Conditions

To comply with Phantom Lighting System warranty policies and ETL Standards, all lighting strips must be used in conjunction with Phantom Lighting transformers. All Phantom lighting transformers are ETL Approved for Class 1 applications and are strongly recommended for proper operation of lighting strips. Phantom transformers should not be located in areas with no ventilation or subject to high ambient temperatures. If ambient temperatures exceed 115°F (46°C) around the transformer, the circuit breakers may nuisance trip due to excessive heat.

CAUTION: FAILURE TO CORRECTLY SIZE PRIMARY AND SECONDARY CONDUCTORS AND/OR OVERLOAD PROTECTION MAY RESULT IN BODILY INJURY OR SERIOUS PROPERTY DAMAGE.

Likewise, Phantom lighting strips should be installed in such a way as to properly dissipate heat. We recommend that you allow a minimum overall 3" set back from the wall or ceiling plane being illuminated. Not only does this clearance allow the heat to escape, but it allows room for installation, servicing, and changing lamps. If you are using exotic wood, veneers, or heat-sensitive fabrics, we suggest increasing this clearance from a 3" to a 5" set back.

If you have any questions or concerns regarding your application, please contact the Phantom Lighting factory, a licensed electrician in your area, or consult the National Electric Code.

