





















## INSTALLATION INSTRUCTIONS (1/2)

### TYPICAL COMPONENTS

-  (1) Projector Supplement
-  (3) Black Male Knobs
-  (1) Curved Washer
-  (4) Washers
-  (4) Black Female Knobs
-  (1) Focal Cone
-  (1) Focal Lens Clip
-  (1) Focal Lens Spacer
-  (2) Focal Lenses
-  (2) Condensing Lenses
-  (1) Glare Shield
-  (1) Mounting Cradle
-  (1) Rotating Ring
-  (1) Projector w/ LED Light Engine
-  (1) IC-Rated Housing
-  (1) Rough-In Ring
-  (1) Cover Plate
-  (3) Sets of Shutters  
(12 Total; Optional)
-  (3) Metal Slides (optional)
-  (1) Metal Gobo (by others)

### READ AND UNDERSTAND THESE INSTRUCTIONS BEFORE INSTALLATION – SAVE THESE INSTRUCTIONS!

These fixtures are intended for installation in accordance with the National Electrical Code and local regulations. To ensure full compliance with local codes and regulations, check with your local electrical inspector before installation. To prevent electrical shock, turn off electricity at fuse box before proceeding. Remove all components from shipping carton. The instructions are in a step by step sequence for correct and easy assembly. Save the shipping carton and packing materials until job is complete.

#### 1. DETERMINE MOUNTING LOCATION

A projector supplement has been provided to illustrate projector performance, location and beam configurations. Determine the exact location and verify adequate space between rafters and depth of ceiling cavity to accommodate housing before proceeding.

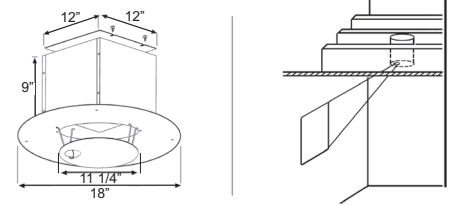

#### 2. CUT OPENING / INSTALL POWER

Using the cardboard template provided as a guide, mark the ceiling lightly with a pencil. Cut a small opening inside the mark to inspect for obstructions. If clear, remove the ceiling material by cutting 1/8" outside the pencil mark. Install wiring before installing housing.

EXISTING CEILING

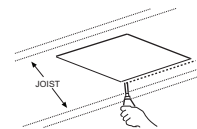

NEW CONSTRUCTION CEILING

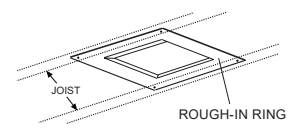

#### 3. INSTALL WOOD BLOCKS AND HOUSING

Create a frame around the projector housing using 1 x 4 wood blocks. Using the drywall screws provided, fasten the float plate to the wood frame. **NOTE: Do not over tighten the screws – it might cause the Float Plate to warp. Countersinking outer flange will reduce floating area.**

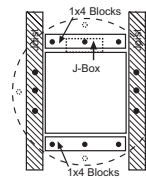

LEFT: TOP VIEW | BELOW: SIDE VIEW

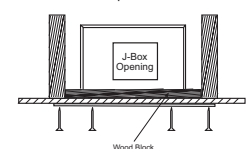

#### 4. WIRE-IN / ATTACH DRIVER ASSEMBLY TO HOUSING

Remove square metal cover from junction box by loosening (2) screws. Remove knock out in junction box and install strain relief fitting before installing supply wiring into junction box. Connect WHITE wire inside junction box to incoming neutral wiring. Connect BLACK wire inside junction box to incoming switch leg. Connect GREEN ground wire inside junction box to incoming ground wire. GRAY & PURPLE wires should remain capped off in junction box unless you are using a remote 0-10V dimming system. If you have selected the onboard dimmer option, the GRAY & Purple wire will not be accessible inside the junction box.

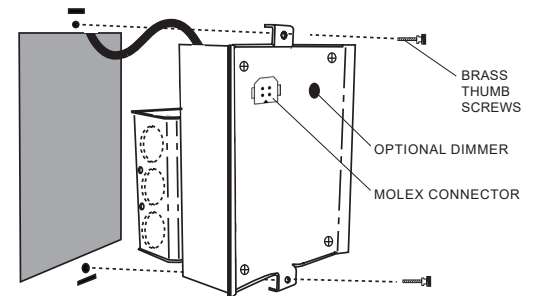

#### 5. INSTALL MOUNTING CRADLE TO ROTATOR RING

Install projector mounting cradle to rotating assembly using (2) black knobs provided. Insert the front pivot pegs on rotator ring into the front pivot holes on cradle. This is your angle pivot point. Install projector into cradle with three holes on the projector face down and secure using black wing nut to center hole.

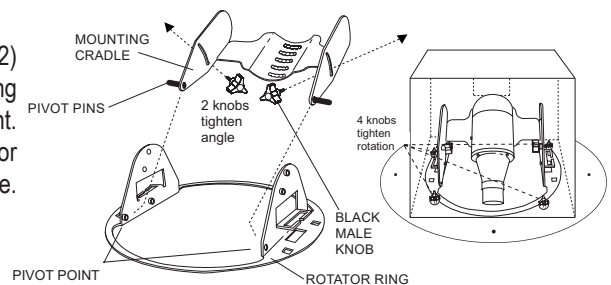

## INSTALLATION INSTRUCTIONS (2/2)

INSTRUCTIONS BEGIN ON REVERSE

### WARRANTY & RETURNS

**WARRANTY:** PHANTOM™ LIGHTING SYSTEM warrants its products against defects in any material and workmanship for one year from the invoice date. PHANTOM™ reserves the right to either repair or replace without charge, any properly installed PHANTOM™ product which falls under normal operating conditions within the specified warranty period for fixtures (excluding lamps) and transformers, provided it is returned to the factory, transportation prepaid, and our inspection determines it to be defective under the terms of the warranty. This warranty covers only equipment manufactured by PHANTOM™ and does not extend to transportation, installation, or replacement charges, nor does it apply to any equipment of another manufacturer used in conjunction with PHANTOM™ equipment. In a progressive policy of research and development we reserve the right to vary and modify specifications without prior notice.

**RETURNS:** Custom fabricated PHANTOM™ products are non-returnable. For all returns (Warranty and Non-Warranty), request an RGA form by email to Sales@PhantomLighting.com. Upon approval an RGA number will be issued. An RGA number does not guarantee that the product is defective or that credit will be issued. Final determination if a product is defective cannot be fully determined until the product is received and inspected before an exchange or credit can be issued. All returned products are shipped prepaid by the customer. If the product is determined as "defective", the product will be repaired or replaced and returned to the customer by UPS® - Ground prepaid by Phantom Lighting. If the product is determined as "not defective", it may be returned to the customer. Products that have been installed cannot be returned. Returns on Phantom products that are not considered custom, parts and accessory items, will be charged a 25% restocking fee. Allow 30 business days from receipt of the product for credit if any to be issued.

### 6. INSTALL PROJECTOR INTO MOUNTING CRADLE

Connect power lead from projector to receptacle located on the J-BOX cover. Install Contour Projector into mounting cradle and secure using (1) black knob. Tighten (4) mounting screws on outer ceiling flange to lock housing into position.

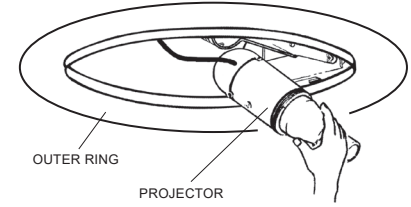

### 7. SET FOCUS AND ADJUST MASKING METHOD

Adjust projector in mounting cradle and adjust confinement mechanism. (See PROJECTOR SUPPLEMENT for specific details regarding setup and adjustment).

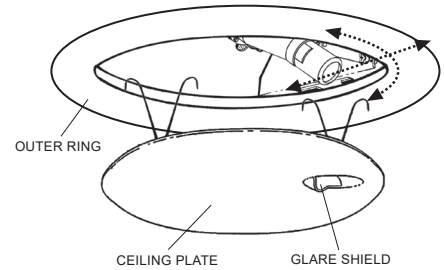

**Note:** Make sure cover plate does not hit projector body or focal cone before adjusting shutters or cutting template.

### 8. INSTALL CEILING PLATE WITH GLARE SHIELD

Install ceiling trim to housing using attached Tosionite springs. Collapse springs with your fingers and insert them directly into the "C" shaped opening located on both sides of the cradle assembly. Allow the panel to gently rest against the ceiling without bumping focal cone. Install optional glare shield and check for flush finish.

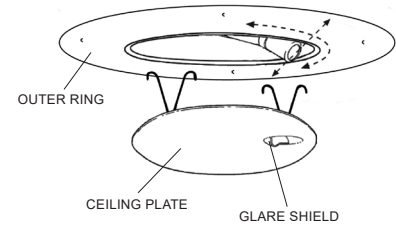

**Note:** Adjust the glare shield as needed to hide all projector components without blocking any of the light.

## WIRING DIAGRAM AND MASKING INFORMATION

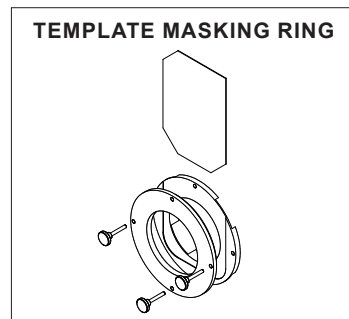
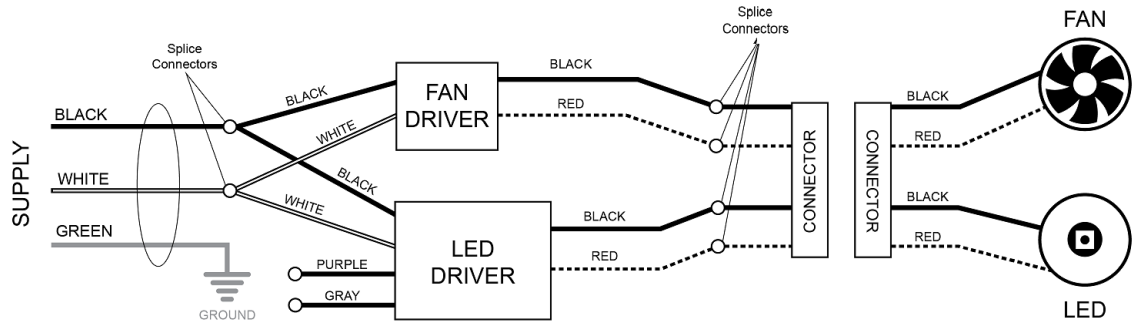

 **TECHNICAL SUPPORT:**  
800.863.1184

**PHANTOM**  
LIGHTING SYSTEM