



ART LIGHTING

CONTOUR  
PROJECTORS



LED

# Projector Supplement

**SAFETY WARNING:** Please read all the instructions in this supplement before proceeding with the installation. This fixture is intended for installation in accordance with the National Electric Codes regulations. To prevent electric shock, turn off electricity at the fuse box before proceeding. These instructions are designed as a general overview and guide for a typical installation. Retain these instructions for future needs and maintenance reference.

If you have any questions or need help identifying the right model for your application, contact tech support at **(800) 863-1184** for assistance.



ETL LISTED

Conforms to UL STD 1598 Requirements  
Certified to CSA STD C22.2 NO.250.0

**PLEASE READ THIS ENTIRE PACKET BEFORE BEGINNING INSTALLATION**

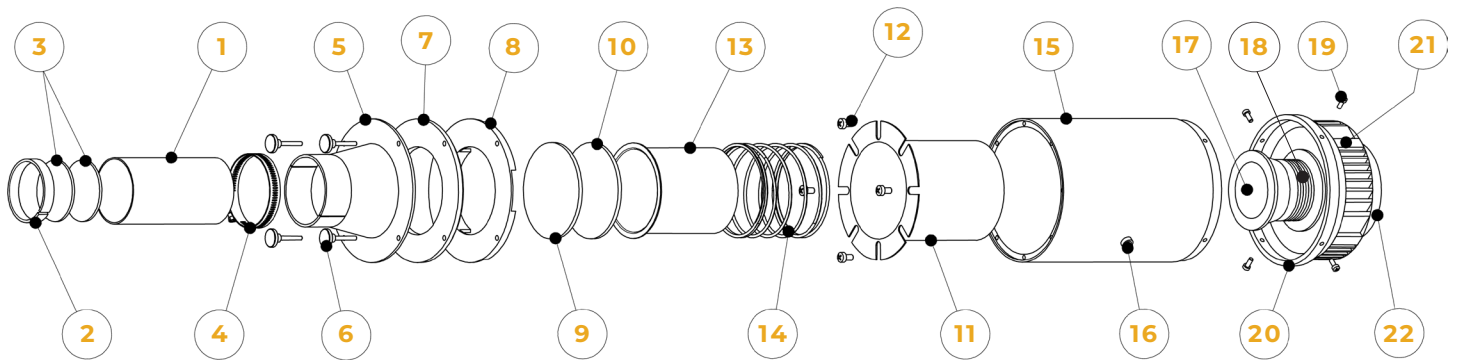

## Exploded View Parts Key

- |                            |                                    |                                |                             |
|----------------------------|------------------------------------|--------------------------------|-----------------------------|
| 1 Focal Cone (1)           | 7 Masking Ring – Front (1)         | 13 Condensing Tube – Inner (1) | 19 Cap Retaining Screws (3) |
| 2 Focal Lens Clip (1)      | 8 Masking Ring – Back (1)          | 14 Condensing Spring (1)       | 20 Back Cap (1)             |
| 3 Focal Lenses (2)         | 9 Condensing Lens – Plano (1)      | 15 Projector Body (1)          | 21 Heat Sink (1)            |
| 4 Focal Hose Clamp (1)     | 10 Condensing Lens – Bi-Convex (1) | 16 Cradle Mount (3)            | 22 Active Cooling Fan (1)   |
| 5 Focal Tapered Cone (1)   | 11 Condensing Tube – Outer (1)     | 17 LED CPC Reflector (1)       |                             |
| 6 Brass Thumb Screws (3-4) | 12 Condensing Tube Screws (2)      | 18 LED Light Source (1)        |                             |

**Note:** Parenthesis after each part name is quantity of parts included/required

### SHUTTER MASKING RING

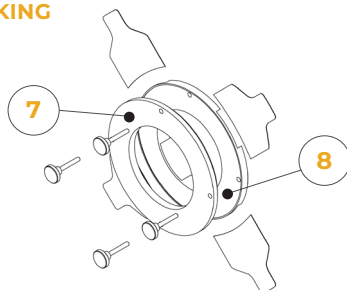

### TEMPLATE MASKING RING

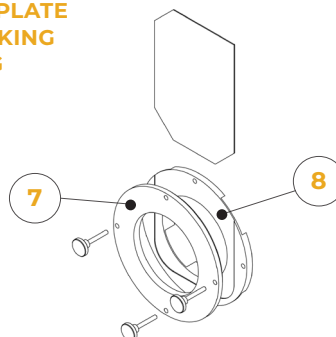

### GOBO MASKING RING

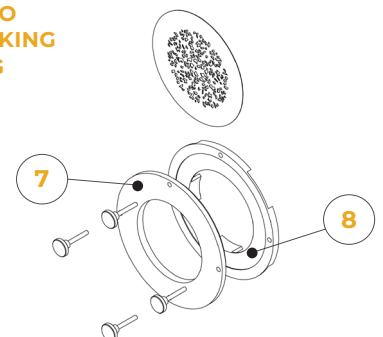

# Determining the Location of Projector in Ceiling

Example: Let's say you have a painting that is 36" High x 24" Wide and it is down from the ceiling roughly 20" to top of canvas. Doing the math, you get 20" + 12" + 4" = 36" out from the wall to the front of the housing as a starting point. The projector can be moved back, left or right as needed to avoid obstructions in the ceiling or to address reflective glare and frame shadows.

An oversized painting can be accommodated in the same way by using two (2) Contour Projectors, mounted at oblique angles. Complimentary design assistance is available from the factory.

## HORIZONTAL TARGET

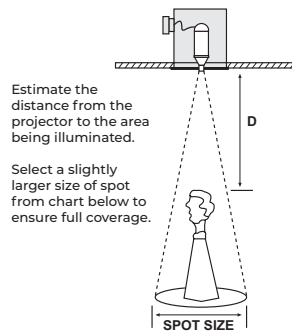

PIN HOLE COVER PLATE (OPTIONAL)

## VERTICAL TARGET

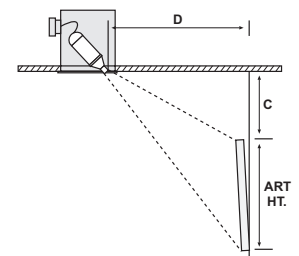

SLOTTED COVER PLATE (STANDARD)

## CALCULATING THROW DISTANCE:

$$C + 1/3 \text{ of art height} + 4 = D$$

C = Distance down from ceiling to top of the art  
D = Distance out from wall where projector mounts  
(See first illustration to the right)

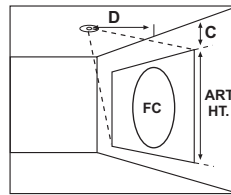

Formula Illustration

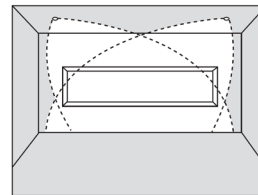

Overlapping Beam Diagram

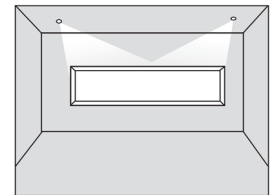

Oversize Beam Spread Result

## CHECKING FOR GLARE (ANGLE OF INCIDENCE)

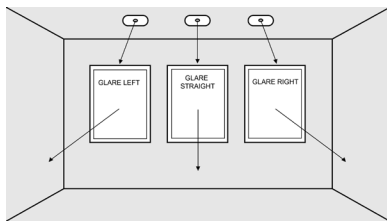

To check varnish glare, use your projector or a bright flashlight and a second person to determine where the best location is. Sometimes the projector will be off-center of the art for best results from viewing angle. Depending on the composition and position of the art, you may not succeed in eliminating objectional glare.

## CHECKING FOR FRAME SHADOW

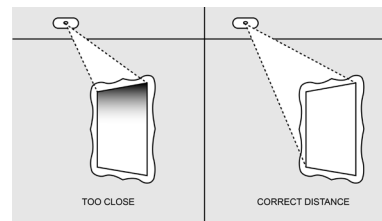

After checking for varnish glare, check to see how deep the frame is. The deeper the frame, the further the distance is between art and light to minimize the shadow. Optimum viewing angle is 45 degrees. Depending on ambient lighting and room conditions, sometimes you may not succeed in eliminating the entire shadow.

## Installing the Lenses

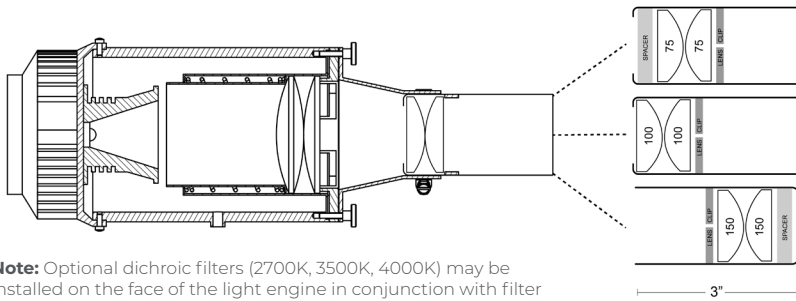

**Note:** Optional dichroic filters (2700K, 3500K, 4000K) may be installed on the face of the light engine in conjunction with filter holder to adjust color temperature. Consult factory for more information on color-changing filters.

## Optimizing Beam Spread

If the art is gone or undetermined, use paper or cardboard taped to the wall to verify your selection. Optimum aiming angle is 45 degrees to the center of the art, and may be adjusted for jobsite conditions, frame shadow, or glare.

When selecting a lens combination or beam spread, the objective of the installation is to cover the art with the smallest projected field of light. Of course, the top corners of the art are your main concern and will dictate the projected field size as shown in the illustration.

It is always best to test before cutting the ceiling or mounting the housing if the art is available. Install the shutters or template when testing so that the correct focus can be established. Once set, open up shutters or remove template to confirm projected field of light is suitable to cover entire work.

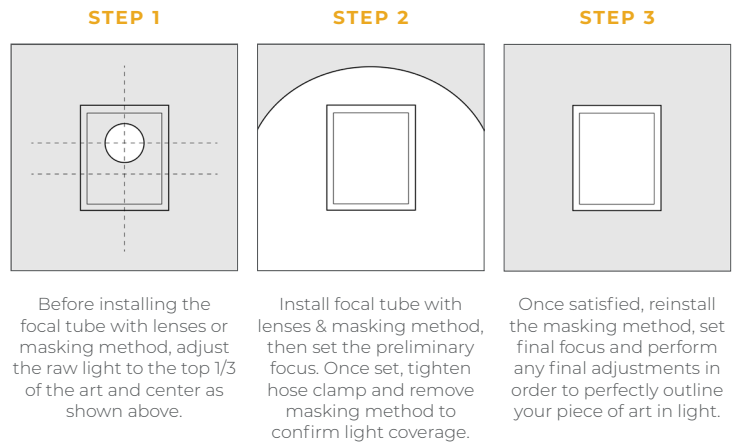

## Electronic LED Driver Information

ERP® electronic drivers are auto-sensing and compatible with TRIAC (forward-phase or leading-edge), ELV (reverse-phase or trailing-edge) and 0-10 V dimmers. TRIAC and ELV dimming only at 120VAC and ELV dimming only at 230VAC. HATCH® electronic drivers used to power the cooling fan are non-dimming. Please consult the factory if you are experiencing any issues.

ERP® and HATCH® electronic drivers are standard on all Phantom™ LED Contour Projectors. These drivers have built-in safety devices that are designed to power down or shut off in the event of a short in the system. This includes output open load, over-current and short-circuit (hiccup), and over-temperature with auto recovery.

Your electrical junction box is divided into two compartments. One compartment contains the two drivers and is sealed at the factory and the other side is the junction box for landing wires and making 120-277V electrical connections by the installer. ERP® and HATCH® electronic drivers are Class 2 rated and comply with ENERGY STAR, DLC (Design Light Consortium) and CA Title 24 technical requirements.

**Factory Side Installation Note:** Molex pin connectors are single-use fittings and must be spliced using a small wire nut or inline crimp connector during driver replacement.

### INSTALLER SIDE WIRING INSTRUCTIONS

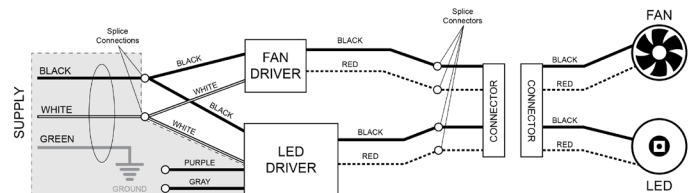

The **black** and **white** and **green** wires on the installer side are for 120-277V 50/60Hz electrical connections. The **gray** and **purple** wires are for 0-10V dimming only and should remain capped off unless connected to a low-voltage dimming device.

### FACTORY SIDE WIRING INSTRUCTIONS

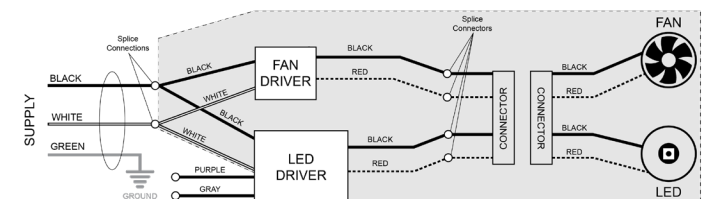

The **black** and **white** wires on the factory side for both the LED driver and fan driver are for 120-277V 50/60Hz electrical connections. The **red** and **black** wires from both the LED driver and fan driver are low-voltage and go to the four conductor Molex connectors feeding power to the projector and fan. In the event of a failure, the factory side is accessible for replacement & care must be taken to maintain polarity.

# Adjustable Shutter Types

The Contour Projector Package comes with 4 different shutter blade sets, for a total of 8 blades. Each shutter type is specially designed to complement a particular beam configuration by adjusting the light to follow the curvature of the lens. This allows for clean, straight lines, regardless of the aiming angle. Combinations of different shutter blades can be used to handle unique situations. In some instances, it may be necessary to modify one or more shutter blades using small scissors or a file.

**Note:** Create a hook using a paper clip to hang extra shutters inside housing for potential future use

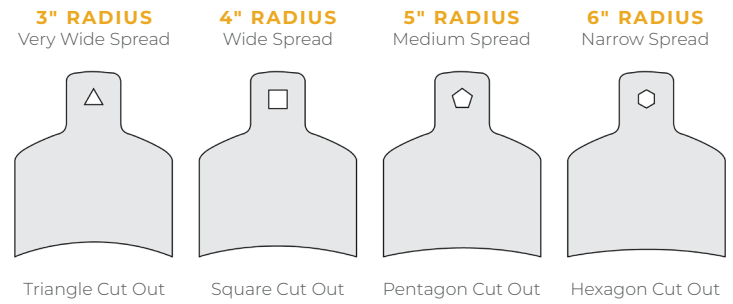

## Shutter Installation

Four metal shutter blades are used for masking simple square and rectangular shaped art. Shutter blades should be installed between the front tapered focal cone (black in color) and the shutter ring (silver in color) on the front of the projector body. Slightly loosen the four thumb screws enough to allow for insertion of the shutter blades while adjusting. The internal lens spring will apply pressure to the shutter blades while adjusting.

**NOTE:** Do not remove all the screws as this will allow the internal condensing lenses to fall and potentially crack. Once adjusted, tighten the thumb screws to lock into position. (See shutter instructions for making tips and recommendations.)

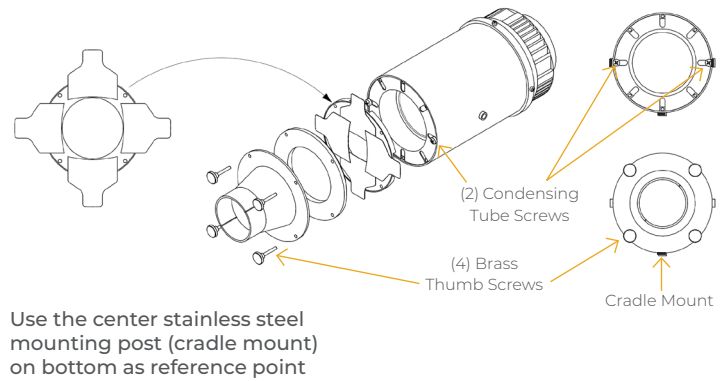

## Custom Templates & Gobos

A custom template is used when multiple paintings are involved or a sculpture is being illuminated. If multiple paintings are being illuminated, the paintings must be on the same wall, such as in a collage format. Cutting templates can be challenging for some installers due to the trial and error approach of cutting the brass. Template instructions and other helpful information is available on our website. If you have any questions, please contact the factory for advice before starting the cutting process.

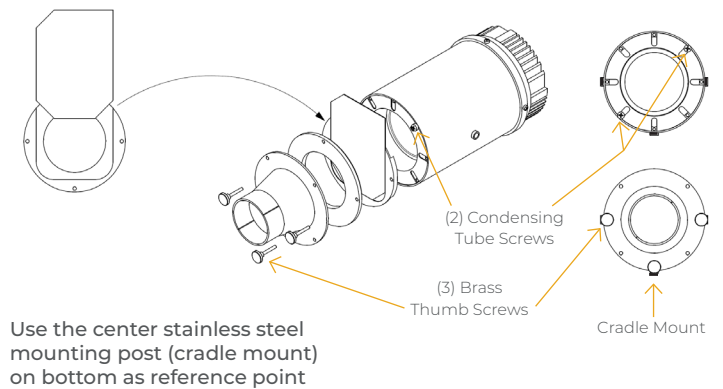

## Setting a Focus

When setting a focus, most people prefer a sharp, hard line of light to outline the art, but sometimes a soft or blurred focus is a good alternative. This is accomplished by adjusting the focusing tube in or out during final adjustments. A soft focus technique is an effective way to illuminate contemporary art without frames or to include ornate frames on traditional works. This is a good way to address issues with spill light, key stoning, or focusing issues when the projector is not in the ideal position. Start with the bottom of the art and find the best average focus overall.

