



Adjustable Shutter Instructions

The Phantom™ Contour Projector is designed with the installer in mind and adjusting shutters to mask the light has never been easier. Our proprietary shutters are designed to accommodate virtually every beam spread and mounting position within reason. They come in four different curvatures specifically designed to address key stoning or curved lines from various focal lengths. Focal length is the distance between the projector and object usually represented in millimeters. The longer the focal length, the narrower the angle of view and the higher the magnification, such as our 150fl configuration. The shorter the focal length, the wider the angle of view and the lower the magnification, such as our 75fl configuration.

Theoretically, as long as the object is within the projected field of light, the object can be illuminated. However, there are limitations due to focusing in extreme situations. Above all, remain calm as this will be a learning experience the first time. After a few minutes, you'll be adjusting shutters like a true professional!

REFER TO THE PROJECTOR SUPPLEMENT TO SELECT LENSES AND BEAM ANGLES

THE FOLLOWING INSTRUCTIONS ADDRESS SOME OF THE BASIC STEPS OF ADJUSTING THE SHUTTERS:

- 1 Orientation of adjustable shutters in the projector
- 2 Where to install the shutters
- 3 Experimenting with various shutters
- 4 Establishing straight lines
- 5 Tightening the shutters
- 6 Saving the extra shutters
- 7 Installing the cover plate

1 Orientation of adjustable shutters in the projector

It is absolutely critical to the adjustment process that you install the four adjustable shutters correctly into the projector to achieve the desired focus. Keep in mind that the internal components of the projector are spring loaded and held in place by the masking ring, spacer and four brass thumb screws.

We DO NOT recommend removing these screws entirely during the adjustment process to prevent damaging internal components or the condensing lenses.

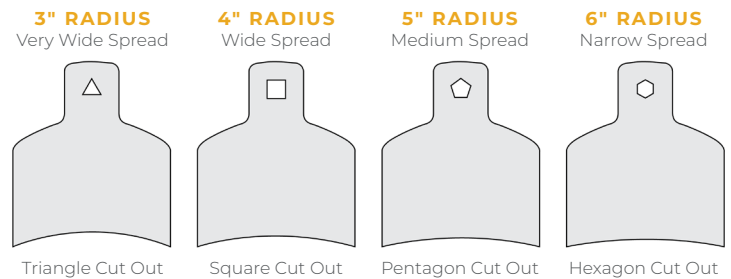

2 Where to install the shutters

FIGURE 1 Start by loosening the four brass thumb screws (two or three turns maximum) or just enough to insert the adjustable shutters. The shutters go in the opening (between the silver front aluminum spacer and the silver shutter ring) and are held in place during adjustment by the internal spring under tension.

- 1 Adjustable shutters (x4)
- 2 Brass thumb screws (x4)
- 3 Silver front aluminum spacer
- 4 Silver shutter ring

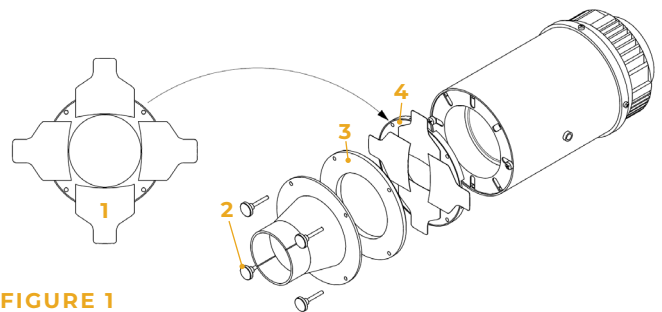

FIGURE 1

3 Experimenting with shutters

FIGURE 2 Installing and adjusting shutters involves some trial and error. That means you simply need to experiment with each shutter type to find the best configuration for your application. After installing the shutters, make a few adjustments to see how the light can be manipulated and curved lines adjusted. The goal is to establish straight lines with the shutters engaged evenly on the central part of the lenses.

Hint: This is also a good time to double check and set the focus. Double check and tighten the three cradle mounting screws as well as the four screws on the rotating ring. Check that the cover plate fits flush with the ceiling and does not hit the projector body, front cone or the shutters (see **FIGURE 5**). If so, you may have to reposition the projector before adjusting the shutters. In the event that the shutter hits the cover plate, simply bend it over to allow for some extra room.

4 Establishing straight lines

The bottom of each shutter has a slight curve, but you'll see once you begin to adjust the light that the lines can be straightened by evenly spacing all 4 shutters on the central part of the lenses. For the straightest lines, make sure that all 4 shutters are inserted an equal distance into the silver shutter ring. You can check this by looking at the distance each tab sticks out of the shutter ring.

5 Tightening the shutters

FIGURE 3 Once you have selected and installed all four adjustable shutters, it's time to gently lock them into position. Start by tightening the brass thumb screws one at a time in a clockwise direction. As you begin to tighten the screws you may see the image shift slightly which is normal and part of the tightening process. Make any final adjustments before they are fully locked into position.

6 Saving the extra shutters

FIGURE 4 Before installing the cover plate, take a paper clip or piece of wire and fashion a hook for hanging the leftover shutters inside the projector housing. The brass thumb screw holding the electrical hatch to the housing is a convenient place to hang the shutters. That way, if you change art or need to make further adjustments in the future, you will have the shutters on hand to accomplish the work.

7 Installing the cover plate

FIGURE 5 Install the cover plate and glare shield. Make sure the glare shield is positioned properly to hide the focal cone and slotted opening without blocking the light inside the glare shield. If this occurs, simply adjust the glare shield as needed to resolve the issue.

FIGURE 2

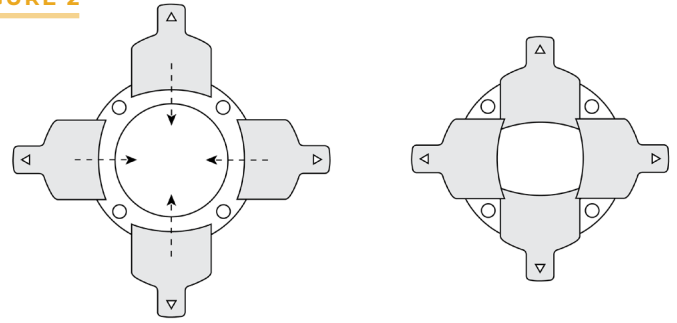

FIGURE 3

- 1 Adjustable shutters (x4)
- 2 Brass thumb screws (x4)
- 3 Silver front aluminum spacer
- 4 Silver shutter ring

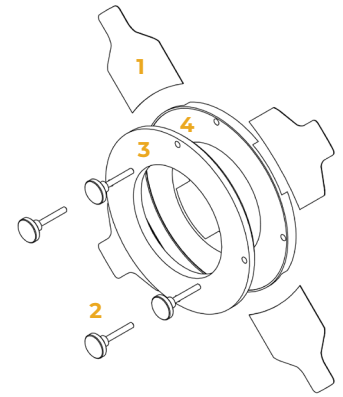
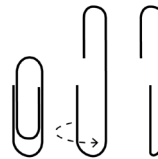

FIGURE 4

Open up a paper clip and bend one side towards you so that the shutters will hang flat against the hatch door inside the housing.



Extra shutters can be hung on either the top (as shown) or bottom brass thumb screws.

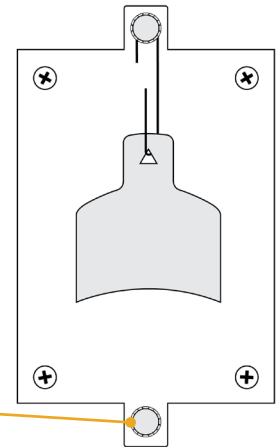

FIGURE 5

